



**अखिल भारतीय आयुर्विज्ञान संस्थान, रायपुर (छत्तीसगढ़)**  
**All India Institute of Medical Sciences, Raipur (Chhattisgarh)**

**खंडन**

यह निविदा अखिल भारतीय आयुर्विज्ञान संस्थान, रायपुर (छ.ग.) के लिये बोलीदाताओं/फर्म/एजेंसी इत्यादी से प्रस्ताव नहीं बल्कि प्रस्ताव प्राप्त करने का निमंत्रण है संविदात्मक दायित्व तब तक नहीं होगा जब तक औपचारिक अनुबंध पर हस्ताक्षर नहीं किया जाता और चयनित बोलीदाताओं/फर्म/एजेंसी इत्यादी के साथ एम्स रायपुर के विधिवत अधिकृत अधिकारियों के द्वारा निष्पादित किया गया हो।

**DISCLAIMER**

This tender is not an offer by the All India Institute of Medical Sciences, Raipur, but an invitation to receive offer from bidders/firm/agency etc. No. contractual obligation whatsoever shall arise from this tender process unless and until as formal contract is signed and executed by duly authorized officers of AIIMS, Raipur with the selected bidder/firm/agency.

---

Tatibandh, G.E. Road, Raipur -492099 (CG),  
Tele: 0771- 2577279, 07712971307  
Website: [www.aiimsraipur.edu.in](http://www.aiimsraipur.edu.in)/[www.eprocure.gov.in](http://www.eprocure.gov.in)  
Email: [store@aiimsraipur.edu.in](mailto:store@aiimsraipur.edu.in)



अखिल भारतीय आयुर्विज्ञान संस्थान, रायपुर (छ.ग.) के  
कॉलेज ऑफ नर्सिंग विभाग हेतु  
“Museum Rack और Cupboard”  
के क्रय/आपूर्ति हेतु तृतीय निविदा आमंत्रण सूचना।

**Notice Inviting Tender for  
"Supply & Installation “Museum Rack & Cupboard” (3<sup>rd</sup> Call)  
For College of Nursing Department"**

**CRITICAL DATE SHEET**

NIT No.	AIIMS/R/CS/CON/2019/23/OT/B
Published Date	23-10-2020, 06.00 PM
Bid Document Download / Sale Start Date	23-10-2020, 06.00 PM
Pre bid meeting	28-10-2020, 03.30 PM
Bid Submission Start Date	07-11-2020, 10.00 AM
Bid Submission End Date	16-11-2020, 06.00 PM
Bid Opening Date	18-11-2020, 03.30 PM

Tatibandh, G.E. Road, Raipur -492099 (CG),  
Tele: 0771- 2577279, 07712971307  
Website: [www.aiimsraipur.edu.in](http://www.aiimsraipur.edu.in)/[www.eprocure.gov.in](http://www.eprocure.gov.in)  
Email: [store@aiimsraipur.edu.in](mailto:store@aiimsraipur.edu.in)



अखिलभारतीयआयुर्विज्ञानसंस्थान, रायपुर, छत्तीसगढ़  
**All India Institute of Medical Sciences, Raipur (Chhattisgarh)**  
Tatibandh, GE Road, Raipur-492 099 (CG)  
Website : [www.aiimsraipur.edu.in](http://www.aiimsraipur.edu.in)  
Tele: 0771- 2971307, e-mail: [store@aiimsraipur.edu.in](mailto:store@aiimsraipur.edu.in)

1. Tenders in Two Bids (Technical & Financial Online bids) are invited on behalf of the, Director, All India Institute of Medical Sciences from interested and eligible service providers for **“Museum Rack & Cupboard”** for the Department of College of Nursing at AIIMS Raipur. Manual bids shall not be accepted.
2. Tender document may be downloaded from AIIMS web site [www.aiimsraipur.edu.in](http://www.aiimsraipur.edu.in) (for reference only) and CPPP site <https://eprocure.gov.in/eprocure/app> as per the schedule as given in CRITICAL DATE SHEET as under.
3. Bid shall be submitted online at CPPP website: <https://eprocure.gov.in/eprocure/app>.
4. Bid documents may be scanned with 100 dpi with black and white option which helps in reducing size of the scanned document.
5. Tenderer who has downloaded the tender from the AIIMS web site [www.aiimsraipur.edu.in](http://www.aiimsraipur.edu.in) and Central Public Procurement Portal (CPPP) eProcurement website <https://eprocure.gov.in/eprocure/app> shall not tamper/modify the tender form including downloaded price bid template in any manner. In case if the same is found to be tempered/modified in any manner, the bids will summarily and tenderer will be liable to be banned from doing business with AIIMS Raipur.
6. **Manual bid shall not be accepted in any circumstance.**
7. The complete bidding process in online bidding, Bidder should be possession of valid digital Signature Certificate (DSC) for online submission of bids. Prior to bidding DSC need to be registered on the website mentioned above.
8. Tenderers are advised to follow the instructions provided in the ‘Instructions to the Tenderer for the e-submission of the bids online through the Central Public Procurement Portal for e Procurement at <https://eprocure.gov.in/eprocure/app>’.
9. Relevant literature pertaining to the items quoted with full specifications should be uploaded, where ever applicable.
10. **Manufacture/OEM/Dealer/Distributor must provide evidence of having supplied same item in government hospital/organization or reputed private hospital/ organizations in India.**
11. **Manufacture/OEM** should be registered and should have average annual turnover at least **₹7,33,600/-** in the last three financial years. Copies of authenticated balance sheet & Profit & loss A/c/Income Expenditure for the past three financial years should be uploaded. In case of Dealer/Distributor/Supplier haven’t minimum annual turnover they should submitted Manufacture/OEM authenticated balance sheet & Profit & loss A/c/Income Expenditure for last three financial years. Dealer/Distributor/Supplier also submitted their authenticated balance sheet & Profit & loss A/c/Income Expenditure for the past three financial years
12. The tender document must be accompanied by copy of PAN, Certificate of firm/company registration, GST registration.
13. The quantity shown against each item is approximate and may vary as per demand of the Institute at the time of placement of order.

14. The bidder must be able to provide the product/items within specified time period as prescribed in the Purchase Order, failing which the PSD will be forfeited. Furthermore on completion of the stipulated time period, Purchase Order will be cancelled and award will be given to another qualified bidder with the negotiated terms & conditions as per Institutes norms.
15. In the event of any dispute or difference(s) between the vendee (AIIMS Raipur) and the vendor(s) arising out of non-supply of material or supplies not found according to the specifications or any other cause what so ever relating to the supply or purchase order before or after the supply has been executed, shall be referred to the Director/AIIMS/Raipur who may decide the matter himself or may appoint arbitrator(s) under the arbitration and conciliation Act 1996. The decision of the arbitrator shall be final and binding on both the parties.
16. The place of arbitration and the language to be used in arbitral proceedings shall be decided by the arbitrator.
17. All disputes shall be subject to Raipur Jurisdiction only.
18. **AIIMS Raipur reserves the rights to accept/reject any bid in full or in part or accept any bid other than the lowest bid without assigning any reason thereof. Any bid containing incorrect and incomplete information shall be liable for rejection.**
19. The Tender/Bid will be opened Store office at AIIMS Raipur Premises.
  - i) Only those financial bids will be opened whose technical bids are found suitable by the expert committee appointed for the concerned instrument/equipment.
  - ii) No separate information shall be given to individual bidders. In incomparable situation, the committee may negotiate price with the technically and financially qualified bidder before awarding the bid.
20. Copies of original documents defining the constitution or legal status, place of registration and principal place of business of the company or firm or partnership, etc. shall be submitted with Tech Bid.
21. **Award of Contract**

AIIMS Raipur will award the contract to the bidder whose quotation has been determined to be substantially responsive and who has bided the lowest evaluated quotation price.

  - i) Notwithstanding the above, AIIMS Raipur reserves the right to accept or reject any quotations and to cancel the bidding process and reject all quotations at any time prior to the award of contract.
  - ii) The bidder whose bid is accepted will be notified of the award of contract prior to expiration of the bid validity period. The terms of the accepted bid shall be incorporated in the purchase order.
22. Normal comprehensive warranty/guarantee and CMC (if applicable) shall be applicable to the supplied goods as per Annexure-I.
23. Rates should be quoted inclusive of packing, forwarding, postage and transportation charges etc.
24. The competent authority reserves all rights to reject the goods if the same are not found in accordance with the required description/ specifications/quality.
25. **A brochure displaying clearly the product is to be attached with the tender if required.**
26. **Earnest Money:**
  - a) As to invite wider participation, earnest money ₹22,000/-of by means of a Bank Demand Draft/ FD, a scanned copy to be enclosed. It is also clarified that the bids submitted without earnest money will be summarily rejected. The DD/FD may be prepared in the name of "All India Institute of Medical Sciences, Raipur (AIIMS

- RAIPUR)". The used instrument must reach at officer of the Stores Officer Gate no. 5, Medical College Building, 2<sup>nd</sup> Floor, AIIMS, Raipur before opening of tender.
- b) No request for transfer of any pervious deposit of earnest money or security deposit or payment of any pending bill held by the AIIMS Raipur in respect of any previous supply will be entertained. Tenderer shall not be permitted to withdraw his bid or modify the terms and conditions thereof. In case the tenderer fail to observe and comply with stipulations made herein or backs out after quoting the rates, the aforesaid amount of earnest money will be forfeited.
- i) Tenders without Earnest Money will be summarily rejected.
- ii) No claim shall lie against the AIIMS Raipur in respect of erosion in the value or interest on the amount of EMD.
- iii) MSME units interested in availing exemption from payment of bid security should submit a valid copy of their registration certificate issued by the concerned NSIC/Udyog Aadhaar. If the bidder is a MSME, it shall declare in the bid document the Udyog Aadhar Memorandum Number issued to it under the MSME Act, 2006. If a MSME bidder do not furnish the UAM Number along with bid documents, such MSME unit will not be eligible for the benefits available under Public Procurement Policy for MSEs Order 2012. But the Party has to provide Performance Security/Security Deposit if Tender is awarded to them.
- iv) The earnest money will be returned/refund to the unsuccessful tenderers after the tender is decided.
- v) EMD should remain valid for a period of 45 days beyond the final bid validity period. When the tenderer agrees to extend the validity of bid, he shall also extend the validity of EMD suitably.
27. In case the supplier requires any elucidation regarding the tender documents, they are requested to contact to the Store Officer, AIIMS Raipur through **e-mail: store@aiimsraipur.edu.in** on or before end date of clarification as per critical date sheet.
28. The earnest money of the successful bidder (after the submission of Security deposit/PSD) and the unsuccessful bidders will be returned to them without any interest.
29. Price Preference Policy and Exemption for submission of various eligibility Criteria documents to the BIDDER Registered under Make in India Initiative:- The Bidder Companies, those have registered under Make in India initiative and producing their products under "**Make in India Policy of Government of India** " shall be given Price Preference as per Govt. of India applicable Rules and Guidelines on submission of relevant certificate (i.e. Make In India Certification) for availing the Price Preference and Exemption for submission of exempted documents against this bid along with their Pre-Qualification Bid Documents. If the no bidder will upload/submit the requested "Make in India" Certificate along with their Bid, it will be treated as open tender bid and no preference shall be given to such BIDDER on producing "Make in India" Certification in later bid stage.
- It is expected that, all the participating BIDDER companies have understanding and prior knowledge about the "Make in India" Initiative and Price Preference Policy of Govt. of India. However, it is once again emphasized that before participating this e-tender please carefully read the "Make in India" Initiative and directives of Govt. of India, since in case if any "**Make in India**" Registered Company will participate against this e-tender, the Price preference as per the same will be given to such participating Bidder company for ensuring necessary compliances of "Make in India" Policy of the Govt. of India.

- The bidders are required to submit the following annexure in compliance of public procurement (Preference to Make in India) order, 2017:
  - Affidavit of self-certification regarding local content (to be provided on own letter head).
30. If an agent submits bid on behalf of the Principal/OEM, the same agent shall not submit a bid on behalf of another Principal/OEM in the same tender for the same item/product. In a tender, either the Indian Agent on behalf of the Principal/OEM or Principal/OEM itself can bid but both cannot bid simultaneously for the same item/product in the same tender.
31. In case the tenderer is not doing business in India, it is duly represented by an agent stationed in India fully equipped and able to carry out the required contractual functions and duties of the supplier including after sale service, maintenance & repair etc. of the goods in question, stocking of spare parts and fast moving components and other obligations, if any, specified in the conditions of contract and/or technical specifications.
32. All goods and services to be supplied and provided for the contract shall have the origin in India or in the countries with which the Government of India has trade relations.  
The word “origin” incorporated in this clause means the place from where the goods are mined, cultivated, grown, manufactured, produced or processed or from where the services are arranged. The country of origin may be specified in the Price Schedule.
33. If there is more than one schedule in the “Schedule of Requirements”, the bidder has the option to submit its bid for any one or more schedules. However, while quoting for a schedule, the bidder shall quote for the complete requirement of goods and services as specified in that particular schedule.
34. Other terms and condition applicable as per manual for procurement of goods 2017& GFR-2017 etc.

**Stores Officer,  
AIIMS Raipur**

---

**Other Terms & Conditions:**

**1. Pre-Qualification Criteria:**

Bidder should be the manufacturer/authorized dealer/Distributor/Trader/ **Supplier of goods. Letter of Authorization from Manufacturer of the goods** and specific to the tender should be uploaded in the prescribed place.

**2. Performance Security Deposit (PSD):**

- a) The successful bidder shall have to submit a Performance Security Deposit (PSD) within 21 days from the date of issue of Letter of Award (LOA). Extension of time for submission of PSD beyond 21 days and up to 45 days from the date of issue of LOA may be given by the competent authority to sign the contract agreement however a penal interest of 15% per annum shall be charged for the delay beyond 21 days. i.e. 22<sup>nd</sup> day after the date of issue of LOA. In case the contractor fails to submit the requisite PSD even after 45 days from the date of issue of LOA the contract shall be terminated duly forfeiting the EMD and other dues, if any payable against the contract. The failed contractor shall be debarred from participating in re-tender (if any) for that item. The Performance security shall be denominated in Indian Rupees.
  - b) Successful supplier/firm should submit Performance Security Deposit in favour of "AIIMS, Raipur" to be received in the Store Office, 2nd Floor, Medical College Building, Tatibandh, Raipur (C.G) Pin-492099 before the date of commencement of supply or 30 days from the date of acceptance of the LOA, whichever is earlier. The Performance Security Deposit shall be furnished in the form of FDR/DD/Bank Guarantee or performance guarantee bond as per proforma given in the tender documents, for an amount covering 10% of the contract value.
  - c) The Performance Security Deposit should be established in favour of "AIIMS Raipur" through any Schedule Bank with a clause to enforce the same on their local branch at Raipur.
  - d) Validity of the Performance Security Deposit shall be for a period of 60 days beyond entire warranty.
- 3. Delivery & Installation:** The successful bidder should strictly adhere to the following delivery schedule Supply, installation & commissioning should be effected **within 45 days** from the date of purchase order and this clause should be strictly adhere to failing which Liquidation Damages will be imposed as per **clause no. 6 hereunder**.
- 4. Part Supply:** No part supply/ wrong supply or short supply will be accepted by the Institute. The Director, AIIMS, Raipur will be the final authority and will have the right to reject full or any part of supply, which is contradictory to the terms and conditions agreed at the time of placement of order. In case of rejection of any supplied items due to nonconformity in quantity and/or quality, Institute will have right to charge liquidated damages, as it deems fit.
- 5.** Purchase Order will be placed as per requirement of institute.
- 6. Penalty:** If the suppliers fails to **Supply/Install & Commission and/or** place any or all the Equipment or perform the service by the specified date as **mentioned** in purchase order, penalty at the rate of **0.5% per week or part thereof delayed** value of goods subject to the maximum of **10% of delayed goods value will be imposed**.

7. **Training and Demonstration (if required):** Suppliers needs to provide adequate training and demonstration at AIIMS Raipur to the nominated person of AIIMS Raipur at their cost. AIIMS Raipur will not bear any training or living expenditure in this regard. The supplier should arrange for regular weekly visit to the AIIMS, Raipur campus by its technical team and assist in maintenance of the item/equipment within warranty period. Assistance limited to locking companies with manufacturer will not be considered sufficient. Training of the Purchaser's Personnel, at the Supplier's plant and/or on-site shall be carried out in assembly, start-up, operation, maintenance and/or repair of the supplied Goods after successful installation, testing, commissioning of the goods. Supplier shall provide necessary training materials and documents.
8. **Responsibility:** The principal as well as its agent will be severally and jointly responsible for ensuring the minimum life span of 10 years for the equipment. Both the said principal abroad and his Indian agent will have the full responsibility for the proper functioning of the equipment/instruments within the warrantee period and thereafter during the life span of the equipment.
9. **Right of Acceptance:** AIIMS, Raipur reserves the right to accept or reject any or all tenders/quotations without assigning any reason there of and also does not bind itself to accept the lowest quotation or any tender. AIIMS, Raipur also reserves the rights to accept all the equipment/instruments in the given tender or only part of it in any given schedule without assigning any reason.
10. **Validity of the bids:** The bids shall be valid for a period of **180 days** from the date of opening of the tender.

In exceptional cases, the tenderers may be requested by the purchaser to extend the validity of their tenders up to a specified period. Such request(s) and responses thereto shall be conveyed by surface mail or by fax/ telex/cable followed by surface mail. The tenderers, who agree to extend the tender validity, are to extend the same without any change or modification of their original tender and they are also to extend the validity period of the EMD accordingly.

11. **Late Tender:** There is **NO PROVISION** of uploading late tender beyond stipulated date & time in the e-tendering system. However, if the necessary EMD in original are not submitted within the scheduled time, the tender shall be declared as late tender and online tender shall not be opened and shall be ignored.
12. **Risk Purchase & Recovery of sums due:**
  - Failure or delay in supply of any or all items as per Requisition / Purchase Order, Specification or Brand prescribed in the tender, shall be treated as '**non-compliance**' or 'breach of contract' and the order in part of full be arranged from alternative source(s) at the discretion of the hospital authority and the difference in price can be recovered from the tenderer.
  - The amount can be recovered from any of his subsequent / pending bills or security Deposit.
  - In case the sum of the above is insufficient to cover the full amount recoverable, the contractor shall pay to the purchaser, on demand the remaining balance due.
13. **Clarification of Bids:** During evaluation of bids, the Purchaser may, at its discretion, ask the bidder for a clarification of its bid. The request for clarification and the response shall



be in writing and no change in prices or substance of the bid shall be sought, offered or permitted.

**14. Communication of Acceptance:** AIIMS, Raipur reserves all right to reject any tender including of those tenderers who fails to comply with the instructions without assigning any reason whatsoever and does not bind itself to accept the lowest or any specific tender. The decision of this Institute in this regard will be final and binding.

**15. Tender Currencies:**

- a. The tenderer supplying indigenous goods or already imported goods shall quote only in Indian Rupees
- b. For imported goods if supplied directly from abroad, prices shall be quoted in any freely convertible currency say US Dollar, Euro, GBP or Yen. As regards price(s) for allied services, if any required with the goods, the same shall be quoted in Indian Rupees only if such services are to be performed /undertaken in India.
- c. Tenders, where prices are quoted in any other currency may not be accepted and are liable to be ignored.
- d. A tenderer quoting imported goods located within India shall produce documentary evidence of the goods having been imported and already located within India (i.e. Bills of Entry for the quoted items and a self-declaration confirming that the quoted items were imported for the purpose of storage in bidder warehouse and for further sale), along with their techno-commercial bid.
- e. In case the tender permits the tenderers to quote their prices in different currencies, all such quoted prices of the responsive tenderers will be converted to a single currency viz., Indian Rupees for the purpose of equitable comparison and evaluation, as per the exchange rates established by the Reserve Bank of India for similar transactions, as on the date of '**Price Tender**' opening.

**16. Discrepancies in Prices:**

- a. If, in the price structure quoted by a tenderer, there is discrepancy between the unit price and the total price (which is obtained by multiplying the unit price by the quantity), the unit price shall prevail and the total price corrected accordingly, unless the purchaser feels that the tenderer has made a mistake in placing the decimal point in the unit price, in which case the total price as quoted shall prevail over the unit price and the unit price corrected accordingly.
- b. If there is an error in a total price, which has been worked out through addition and/or subtraction of subtotals, the subtotals shall prevail and the total corrected;
- c. If, as per the judgement of the purchaser, there is any such arithmetical discrepancy in a tender, the same will be suitably conveyed to the tenderer by registered / speed post. If the tenderer does not agree to the observation of the purchaser, the tender is liable to be ignored.

**17. Guarantee/Warranty, Service, Maintenance:** Suppliers must give comprehensive onsite warranty for **01 year** from the date of successful installation of item/equipment against manufacturing defects. In the installation report the model number of instrument and all spares parts/ accessories numbers should be in the line of purchase order. If any item covered under warranty fails, the same shall be replaced free of cost including all the applicable charges (shipping cost both ways).

- 18. Inspection and Testing:** - The purchaser and/or its nominated representative(s) will, without any extra cost to the purchaser, inspect and/or test the ordered good sand the related services to con firm their conformity to the contract specifications and other quality control details incorporated in the contract. The purchaser shall inform the supplier in advance, in writing, the purchaser's programme for such inspection and, also the identity of the officials to be deputed for this purpose. The cost towards the transportation, boarding & Lodging will be borne by the seller and/or its nominated representative(s).
- a. The Technical Specification incorporated in the contract shall specify what inspection sand tests are to be carried out and, also, where and how they are to be conducted. If such inspections and tests are conducted in the premise soft he supplier or its subcontractor(s), all reasonable facilities and assistance, including access to relevant drawings, design details and production data, shall be furnished by the supplier to the purchaser's inspector at no charge to the purchaser.
  - b. If during such inspections and tests the contracted goods fail to conform to the required specifications and standards, the purchaser's inspect or may reject the and the supplier shall either replace the rejected goods or make all alterations necessary to meet the specifications and standards, as required, free of cost to the purchaser and resubmit the same to the purchaser's inspector for conducting the inspections and tests again.
  - c. In case the contract stipulates pre-dispatch inspection of the ordered goods at supplier's premises, the supplier shall put up the goods for such inspection to the purchaser's inspector well ahead of the contractual delivery period, so that the purchaser's inspector is able to complete the inspection within the contractual delivery period.
  - d. If the supplier tenders the goods to the purchaser's inspector for inspection at the last moment without providing reasonable time to the inspector for completing the inspection within the contractual delivery period, the inspector may carry out he inspection and complete the formality beyond the contractual delivery period at the risk and expense of the supplier. The fact that the goods have been inspected after the contractual delivery period will not have the effect to keeping the contract a live and this will be without any prejudice to the legal rights and remedies available to the purchaser under the terms& conditions of the contract.
  - e. The purchaser's/consignees contractual right to inspect, test and, if necessary, reject the goods after the goods' arrival at the final destination shall have no bearing of the fact that the goods have previously been inspected and cleared by purchaser's inspect or during pre-dispatch inspection mentioned above.
  - f. Goods accepted by the purchaser/consignee and/or its inspector at initial inspection and in final inspection in terms of the contract shall in no way dilute purchaser's/consignee's right to reject the same later, if found deficient in terms of the comprehensive warranty clause of the contract, as incorporated.
- 19. Insolvency etc.:** In the event of the firm being adjudged insolvent or having a receiver appointed for it by a court or any other under the Insolvency Act made against them or in the case of a company the passing any resolution or making of any order for winding up, whether voluntary or otherwise, or in the event of the firm failing to comply with any of the conditions herein specified AIIMS, Raipur shall have the power to terminate the contract without any prior notice.
- 20. Force Majeure:** If, at any time during the subsistence of this contract, the performance in whole or in part by either party of any obligation under this contract is prevented or delayed by reasons of any war or hostility, act of public enemy, civil commotion, sabotage, fire, floods, exception, epidemics, quarantine restriction, strikes

lockout or act of God (hereinafter referred to as events) provided notice of happening of any such eventuality is given by party to other within 21 days from the date of occurrence thereof, neither party shall by reason of such event be entitled to terminate this contract nor shall either party have any claim for damages against other in respect of such non-performance or delay in performance and deliveries.

Further, that if the performance in whole or in part of any obligation under this contract is prevented or delayed by reason of any such event for a period exceeding 60 days, AIIMS, Raipur may, at list option to terminate the contract.

- 21. Subletting of Contract:** The firm shall not assign or sublet the contract or any part of it to any other person or party without having prior permission in writing of AIIMS, Raipur, which will be at liberty to refuse if thinks fit. The tender is not transferable.
- 22. Packing:** Goods must be securely and adequately packed and protected in order to prevent damage, otherwise all losses and /or damage resulting from inadequate packing and/or inadequate protection or inadequate marking shall be borne by seller/seller's Principal abroad. The supplier shall mark each package on three sides with indelible paint of proper quality as below:-
- a. Purchase Order number and date.
  - b. Brief description of goods including quantity.
  - c. Purchaser's name and full address.
  - d. Supplier's name and full address.

**23. Terms of payment:**

Payment shall be made subject to recoveries, if any, by way of liquidated damages or any other charges as per terms & conditions of contract in the following manner.

**A. Payment for Domestic Goods Or Foreign Origin Located Within India.**

- (a) **On delivery:** 70% payment of the contract price shall be paid on receipt of goods in good condition at the consignee premises and upon the submission of the following documents:
- i) Four copies of suppliers invoice showing contract number, goods description, quantity, unit price and total amount with revenue stamp.
  - ii) Two copies of packing list identifying contents of each package.
  - iii) Two copies of delivering challan.
  - iv) Certificate of origin.
  - v) Manufacturer's own factory inspection report.

- (b) **On Acceptance:** Balance 30% payment would be made against successful acceptance of goods to be issued by the consignees subject to recoveries, if any, on account of non-rectification of defects/deficiencies not attended by the supplier or otherwise.

**B. Payment For Imported Goods:** Payment for foreign currency portion shall be made in the currency as specified in the contract in the following manner:

- a. **On delivery:** 70% payment of the contract price shall be paid on receipt of goods in good condition at the consignee premises **Fedwire or SWIFT** transfer in favour of the supplier in a bank in his country and upon submission of documents specified here under:

- i. Four copies of suppliers invoice showing contract number, goods description, quantity, unit price and total amount with revenue stamp.
  - ii. Two copies of packing list identifying contents of each package.
  - iii. Two copies of delivering challan.
  - iv. Certificate of origin.
  - v. Bill of Entry
  - vi. Bank Account and details of Supplier Bank.
  - vii. Manufacturer's own factory inspection report.
- b. **On Acceptance:** Balance 30% payment would be made against successful acceptance of goods to be issued by the consignees **Fedwire or SWIFT** transfer in favour of the supplier in a bank in his country subject to recoveries, if any, on account of non-rectification of defects/deficiencies not attended by the supplier or otherwise.
- C. Where there is a statutory requirement for tax deduction at source, such deduction towards income tax and other tax as applicable will be made from the bills payable to the supplier at rates as notified from time to time.
- D. No payment shall be made for rejected stores. Rejected equipment's must be removed by the supplier within two weeks of the date of issue of rejection advice at their own cost & replace immediately. In case these are not removed these will be auctioned at the risk and responsibility of the suppliers without notice.

**24. Custom Duty on Imported Goods:**

In respect of imported goods, the tenderers shall also specify separately the total amount of custom duty (without concession rate) which shall form part of the bid price. The tenderers should also indicate correctly the rate of custom duty applicable for the goods in question and the corresponding Indian Customs Tariff Number. Where customs duty is payable, the contract should clearly stipulate the quantum of duty payable etc. in unambiguous terms. AIIMS, Raipur is eligible for concessional rate of custom duty. Necessary certificate will be issued on demand. **However, the bidders shall quote full rates of custom duty on the BOQ without making any provision for exemption. AIIMS, Raipur will not make any arrangements for clearance of imported goods at the airport.**

**25. Custom Duty Reimbursement:** The supplier will pay the customs duty wherever applicable, which will be reimbursed by purchaser as per documentary evidence. The custom duty exemption certificate will be provided to the supplier as and when required.

**26. Good & Service Tax:**

1. GST rates applicable on the quoted item may please be mentioned in the bid document.
2. It may be confirm if there is any (Upward/Reduction) in the Basic Price structure. Bidders are required to pass the Input Credit as per the following Anti Profiteering Clause of GST.

**“Upon Implementation of GST, any reduction in the rate of tax on supply of goods or service or the benefit of input tax credit shall be passed on to AIIMS Raipur by way of commensurate reduction in the prices”.**

3. **HSN Code** for each item should be clearly mentioned on BoQ/Financial Bid.

**27. Fall Clause:**

1. Prices charged for supplies under Rate Contract by the supplier should in no event exceed the lowest prices at which he bids to sell or sells the stores of identical description to any other State Government/DGS&D/Public Undertaking during the period of the contract.
2. If at any time during the period of contract, the prices of tendered items is reduced or brought down by any law or Act of the Central of State government, the supplier shall be bound to inform Purchasing Authority immediately about such reduction in the contracted prices, in case the supplier fails to notify or fails to agree for such reduction of rates, the Purchasing authority will revise the rates on lower side. If there is a price increase for any product after quoting the rates, the bidder will have to supply the item as per quoted rates. This office will not accept any higher rates after wards.
3. If at any time during the period of contract, the supplier quotes the sale price of such goods to any other State Govt./DGS&D and Pubic Undertakings at a price lower than the price chargeable under the rate contract he shall forthwith notify such reduction to Purchasing Authority and the prices payable under the rate contract for the equipment's supplied from the date of coming into force of such price stands correspondingly reduced as per above stipulation.
4. Any deviation in the material or specifications from the accepted terms may liable to be rejected and the suppliers need to supply all the goods in the specified form to the satisfaction/ specifications specified in the Purchase order and demonstrate at the their own cost.

**28. Arbitration:**

If any difference arises concerning this agreement, its interpretation on payment to the made there under, the same shall be settled out by mutual consultation and negotiation. If attempts for conciliation do not yield any result within a period of 30 days, either of the parties may make a request to the Director, AIIMS Raipur to settle the dispute by Sole Arbitrator. Sole arbitrator will be appointed by the Director, AIIMS Raipur. The provision of Arbitration and Conciliation Act, 1996 and the rule framed there under and in force shall be applicable to such proceedings.

**29. Option Clause/ Tolerance Clause:**

- a. At the time of awarding the contract, the purchaser reserves the right to increase or decrease by up to 25% to 30%, the quantity of goods and services mentioned in the schedule (s) in the "Schedule of Requirements" (rounded off to-next whole number) without any change in the unit price and other terms & conditions quoted by the bidder.
- b. If the quantity has not been increased at the time of the awarding the contract, the purchaser reserves the right to increase by 25% to 30%, the quantity of goods and services mentioned in the contract (rounded off to next whole number) without any change in the unit price and other terms & conditions mentioned in the contract, during the currency of the contract.
- c. **Repeat Order Clause:**-If essentially stipulated by indenting authority, which is duly approved by competent authority of AIIMS Raipur. Then purchaser retains the right to place the repeat order for an additional quantity of the equipment with the same rate and terms of contract.

**30. Legal Jurisdiction:**

The agreement shall be deemed to have been concluded in Raipur, Chhattisgarh and all obligations hereunder shall be deemed to be located at Raipur, Chhattisgarh and Court within Raipur, Chhattisgarh will have Jurisdiction to the exclusion of other courts.

- 31.** Rate wise comparison of the quotes will be made and L1\* for each item (if Two Equipment's) will be determined accordingly. In this context, final decision of the committee will be binding on all and no claim in this regard will be entertained. The quantity indicated is tentative and may vary, and any decision in this regard by Director AIIMS Raipur shall be final.
- 32. L1 firm will be decided on the basis of total price of item FOR at AIIMS Raipur (including all taxes & duty) Warranty 1 Years.**

**Stores Officer,  
AIIMS Raipur (C.G)**

---

### **Technical Bid**

The following documents are required to upload by the Bidder along with Technical Bid as per the tender document:

- a) Scan copy of **EMD cost** must be uploaded.
- b) Please **state whether the bidder** is Manufacture/OEM/Distributor/Dealer/Supplier relevant document should be uploaded.
- c) In case of Distributor/Dealer/Supplier must be upload tender specific authorization certificate from OEM/ manufacturer should be uploaded.
- d) In case of Distributor/Dealer/Supplier must be upload Manufacture/OEM's annual turnover & balance sheet of last three year duly certified by CA as mentioned in tender document should be uploaded.
- e) Copy of PAN Card **should be uploaded (Bidder)**.
- f) Firm/Company registration certificate should be uploaded **(Bidder)**.
- g) The GST registration details may be furnished **(Bidder)**.
- h) Income Tax Return of last three years should be uploaded **(Bidder)**.
- i) Signed and scanned copy of Purchase Order (without hidden price) of the same supplied machine (of quoted make and Model) issued Institution/Organization after a minimum period of six months of installation. **(Bidder/ OEM/ Manufacturer)**.
- j) Signed and scanned copy of User List (List of Govt./Semi Govt./Reputed Pvt. Hospital/Organization) where quoted model of the items has been supplied and installed as per the Annexure I. **(Bidder / OEM/ Manufacturer)**
- k) Annual turnover & balance sheet of last three year duly certified by CA as mentioned in tender document should be uploaded**(Bidder)**.
- l) Form A duly filled by the Bidder.
- m) "Declaration by the Bidder"as mentioned in tender document should be uploaded **(Bidder)**.
- n) Original Technical Catalogue of the quoted model only with full specifications etc. **should be uploaded.**
- o) Have you previously supplied these items to any government/ reputed private organization/institution? If yes, attach the relevant poof. Please provide a certificate on letter head that you have not quoted the price higher than previously supplied to any government Institute/Organization/reputed Private Organization or DGS&D rate in recent past.

### **PRICE BID**

- (a) Price bid in the form of BOQ\_XXXX.xls.

**Annexure I****Format of Experience certificate**

Sl. No	Contract No./Supply order No	Name of the Purchaser	Description of work	Qty. Supplied	Value of Contract

Place:.....

(Signature of Bidder with seal)

Date:.....

Name :

Seal :

Address :

**Note:**

- User List (List of Govt./Semi Govt./Reputed Pvt. Hospital/Organization) where quoted model of the items has been supplied and installed.
- Copies of supply orders of the same models quoted (without hidden price for rate justification).



**Form-A****PARTICULARS FOR REFUND OF EMD TO SUCCESSFUL/UNSUCCESSFUL BIDDER  
RTGS/National Electronic Fund Transfer (NEFT)Mandate Form**

1	Name of the Bidder	
2	Permanent Account No(PAN)	
3	Particulars of Bank Account	
	a) Name of the Bank	
	b) Name of the Branch	
	c) Branch Code	
	d) Address	
	e) City Name	
	f) Telephone No	
	g) NEFT/IFSC Code	
	h) RTGS Code	
	i) 9 Digit MICR Code appearing on the cheque book	
	j) Type of Account	
	k) Account No.	
4	Email id of the Bidder	
5	Complete Postal Address of the bidder	

Place:.....

(Signature of Bidder with seal)

Date:.....

Name :

Seal :

Address :

### **Declaration by the Bidder:**

1. I am authorized signatory of the agency/firm and am competent to sign this declaration and execute this tender document.
2. The information / documents furnished along with the above application are true and authentic to the best of my knowledge and belief. I / we, am / are well aware of the fact that furnishing of any false information / fabricated document would lead to rejection of my tender at any stage besides liabilities towards prosecution under appropriate law
3. I/We have downloaded the tender from the internet site and I/We have not tampered /modified the tender documents in any manner. In case the same is found tampered/ modified, I/We understand that my/our offer shall be summarily rejected and I/We are liable to be banned from doing business with AIIMS Raipur and/or prosecuted as per laws.
4. I/We further undertake that our firm/company is fulfilling all the terms and conditions/eligibility criteria obvious/explicit or implied/implicit recorded anywhere in the tender document. If at any time including the currency of the Contract, any discrepancy is found relating to our eligibility or the process of award of the contract criteria, this may lead to termination of contract and/or any other action deemed fit by the Institute.
5. I/We further undertake that none of the Proprietor/Partners/Directors of the Agency/agency was or is Proprietor or Partner or Director of the Agency with whom the Government have banned /suspended/blacklisted business dealings. I/We further undertake to report to the Faculty-in-Charge Procurement Cell, AIIMS, Patna immediately after we are informed but in any case not later 15 days, if any Agency in which Proprietor/Partners/Directors are Proprietor or Partner or Director of such an Agency which is banned/suspended in future during the currency of the Contract with you.
6. No other charges would be payable by Client and there would be no increase in rates during the Contract period.

Place:.....

(Signature of Bidder with seal)

Date:.....

Name :

Seal :

Address :

**MANUFACTURER'S / PRINCIPAL'S AUTHORIZATION FORM**

To,  
The Stores Officer,  
All India Institute of Medical Sciences Raipur (C.G)

Dear Sir,

Tender No. : \_\_\_\_\_.

Equipment Name : \_\_\_\_\_.

3. We, \_\_\_\_\_ who are established and reputable manufacturers of \_\_\_\_\_, having factories at \_\_\_\_\_ and \_\_\_\_\_, hereby authorize Messrs. (Authorized Dealer/Distributor/Supplier) \_\_\_\_\_ (name and address of agents) to bid, negotiate and conclude the contract with you against this tender for the above goods manufactured by us.
4. No company or firm or individual other than Messrs. \_\_\_\_\_ are authorized to bid, negotiate and conclude the contract in regard to this business against this specific tender.
5. We also hereby undertake to provide full guarantee/warranty /Comprehensive Annual Maintenance Contract as agreed by the bidder in the event the bidder is changed as the dealers or the bidder fails to provide satisfactory after sales and service during such period of Comprehensive Warranty / Comprehensive Annual Maintenance Contract and to supply all the spares/ accessories / consumables etc. during the said period.
6. We hereby extend our full guarantee and warranty as per the conditions of tender for the goods bided for supply against this tender by the above firm.

The authorization is valid up to \_\_\_\_\_

Yours faithfully,

(Name)

For and on behalf of M/s. \_\_\_\_\_

(Name of manufacturers)/Principal

**ANNEXURE-A****Technical Specifications for Museum Rack and Cupboard**

<b>Sl. No.</b>	<b>Item Descriptions</b>
<b>1</b>	<p><b>Museum rack (Wide) with complete installation service of 1 year.</b>            Made up of polished Turfan glass 10mm (ISI marked) Size: Height 1981.2mm x Width 914.4mm x Depth 914.4mm (with base ply height 152.4mm) Ply should be 18mm ISI mark water resistant with one side 1mm sunmica pasted and other side 0.8mm. The edges should be covered with 2mm and 1mm edge band. The 16 cell glass partition with two view (with each cell size height 447.2mm x width 411.6mm x depth 442.2mm) with steel support bolts and complete electric work with 2 LED lamps of 18 watt. (10mm dimension error may be exempted).</p>
<b>2</b>	<p><b>Museum skeleton chamber with backdoor and complete installation service of 1 year.</b>            Made up to Turfan glass 10mm (ISI marked) Size : Height 1981.2mm x Width 431.8mm x Depth 431.8mm (with base ply height 152.4mm and cone height 203.2mm) Ply should be 18mm ISI mark water resistant with one side 1mm sunmica pasted and other side 0.8mm. The edges should be covered with 2mm and 1mm edge band with steel support bolts and complete electric work with 2 LED lamps of 18 watt. (10mm dimension error may be exempted)</p>
<b>3</b>	<p><b>Storage Cupboard with doors and 18mm polished Granite top coverage of under sink area with steel handles (Cupboard Body, Doors and shelves made of Exterior grade particle board of 18mm as per design enclosed) , good quality auto hinges 2 nos. On each door should be provided. 1 year warranty from installation.</b></p>

**NOTE:** Manufacturer firm should be Member of BIFMA/SISMA International.  
 Manufacturer should be ISO 9001, 14001, 18001, Green guard certified.



**2. Museum skeleton chamber**

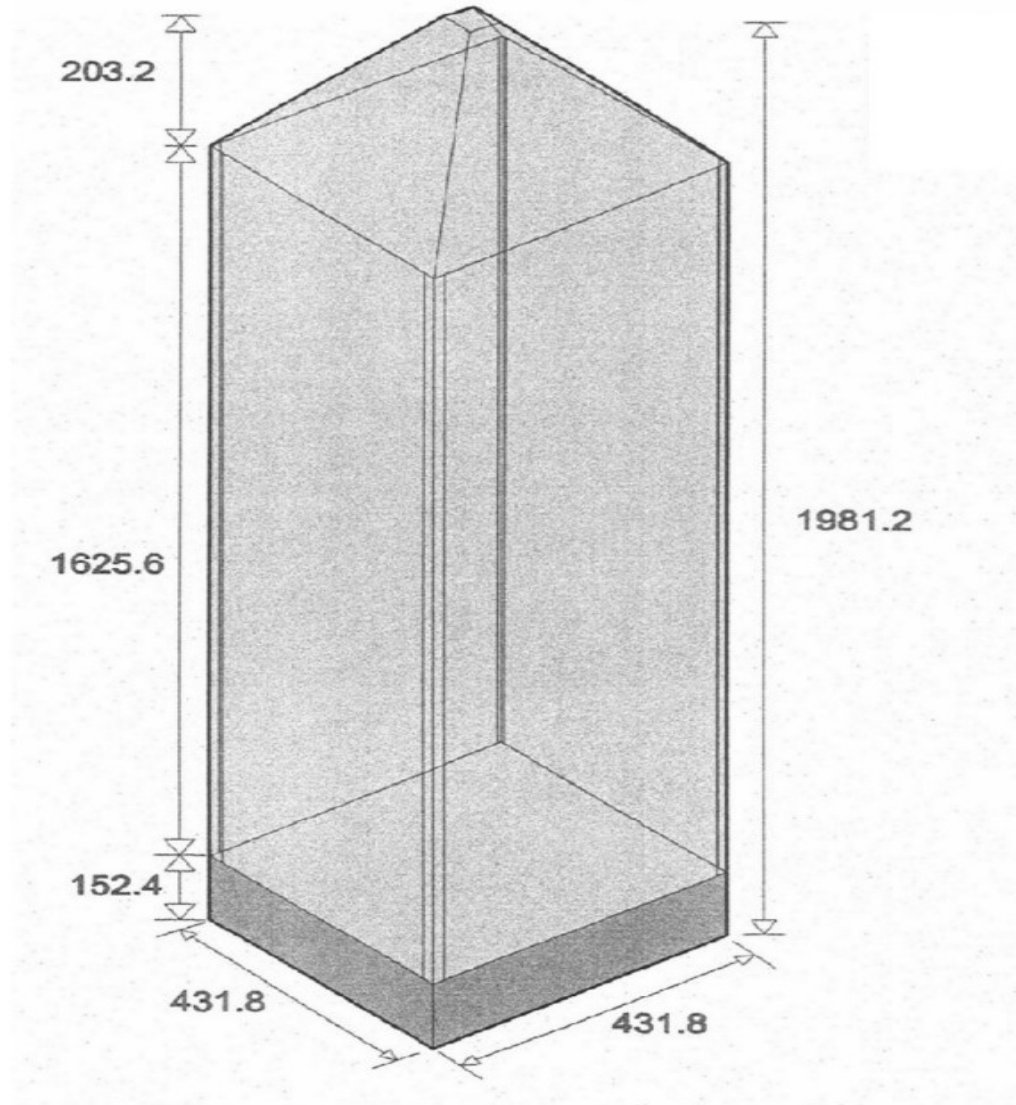

### 3. Storage Cupboard with doors

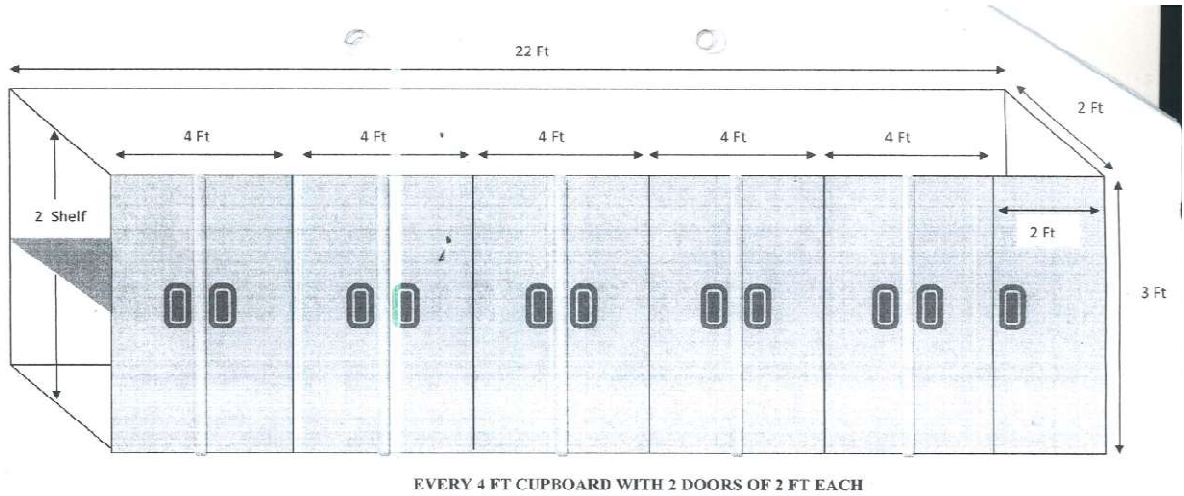

*Handwritten signature and date:*  
23/01/2020

TENTATIVE LAYOUT OF CUPBOARD

### **Instructions for Online Bid Submission:**

The bidders are required to submit soft copies of their bids electronically on the CPP Portal, using valid Digital Signature Certificates. The instructions given below are meant to assist the bidders in registering on the CPP Portal, prepare their bids in accordance with the requirements and submitting their bids online on the CPP Portal.

More information useful for submitting online bids on the CPP Portal may be obtained at: <https://eprocure.gov.in/eprocure/app>.

#### **REGISTRATION**

- 1) Bidders are required to enroll on the e-Procurement module of the Central Public Procurement Portal (URL: <https://eprocure.gov.in/eprocure/app>) by clicking on the link "Online bidder Enrolment" on the CPP Portal which is free of charge.
- 2) As part of the enrolment process, the bidders will be required to choose a unique username and assign a password for their accounts.
- 3) Bidders are advised to register their valid email address and mobile numbers as part of the registration process. These would be used for any communication from the CPP Portal.
- 4) Upon enrolment, the bidders will be required to register their valid Digital Signature Certificate (Class II or Class III Certificates with signing key usage) issued by any Certifying Authority recognized by CCA India (e.g. Sify/nCode / eMudhra etc.), with their profile.
- 5) Only one valid DSC should be registered by a bidder. Please note that the bidders are responsible to ensure that they do not lend their DSC's to others which may lead to misuse.
- 6) Bidder then logs in to the site through the secured log-in by entering their user ID / password and the password of the DSC / e-Token.

#### **SEARCHING FOR TENDER DOCUMENTS**

- 1) There are various search options built in the CPP Portal, to facilitate bidders to search active tenders by several parameters. These parameters could include Tender ID, Organization Name, Location, Date, Value, etc. There is also an option of advanced search for tenders, wherein the bidders may combine a number of search parameters such as Organization Name, Form of Contract, Location, Date, Other keywords etc. to search for a tender published on the CPP Portal.
- 2) Once the bidders have selected the tenders they are interested in, they may download the required documents / tender schedules. These tenders can be moved to the respective 'My Tenders' folder. This would enable the CPP Portal to intimate the bidders through SMS / e-mail in case there is any corrigendum issued to the tender document.
- 3) The bidder should make a note of the unique Tender ID assigned to each tender, in case they want to obtain any clarification / help from the Helpdesk.

#### **PREPARATION OF BIDS**

- 1) Bidder should take into account any corrigendum published on the tender document before submitting their bids.
- 2) Please go through the tender advertisement and the tender document carefully to understand the documents required to be submitted as part of the bid. Please note the
- 3) Number of covers in which the bid documents have to be submitted, the number of documents - including the names and content of each of the document that need to be submitted. Any deviations from these may lead to rejection of the bid.



- 4) Bidder, in advance, should get ready the bid documents to be submitted as indicated in the tender document / schedule and generally, they can be in PDF / XLS / RAR / DWF/JPG formats. Bid documents may be scanned with 100 dpi with black and white option which helps in reducing size of the scanned document.
- 5) To avoid the time and effort required in uploading the same set of standard documents which are required to be submitted as a part of every bid, a provision of uploading such standard documents (e.g. PAN card copy, annual reports, auditor certificates etc.) has been provided to the bidders. Bidders can use “My Space” or “Other Important Documents” area available to them to upload such documents. These documents may be directly submitted from the “My Space” area while submitting a bid, and need not be uploaded again and again. This will lead to a reduction in the time required for bid submission process.

#### **SUBMISSION OF BIDS**

- 1) Bidder should log into the site well in advance for bid submission so that they can upload the bid in time i.e. on or before the bid submission time. Bidder will be responsible for any delay due to other issues.
- 2) The bidder has to digitally sign and upload the required bid documents one by one as indicated in the tender document.
- 3) Bidder has to select the payment option as “offline” to pay the tender fee / EMD as applicable and enter details of the instrument.
- 4) Bidder should prepare the EMD as per the instructions specified in the tender document. The original should be posted/couriered/given in person to the concerned official, latest by the last date of bid submission or as specified in the tender documents. The details of the DD/any other accepted instrument, physically sent, should tally with the details available in the scanned copy and the data entered during bid submission time. Otherwise the uploaded bid will be rejected.
- 5) Bidders are requested to note that they should necessarily submit their financial bids in the format provided and no other format is acceptable. If the price bid has been given as a standard BoQ format with the tender document, then the same is to be downloaded and to be filled by all the bidders. Bidders are required to download the BoQ file, open it and complete the white coloured (unprotected) cells with their respective financial quotes and other details (such as name of the bidder). No other cells should be changed. Once the details have been completed, the bidder should save it and submit it online, without changing the filename. If the BoQ file is found to be modified by the bidder, the bid will be rejected.
- 6) The server time (which is displayed on the bidders’ dashboard) will be considered as the standard time for referencing the deadlines for submission of the bids by the bidders, opening of bids etc. The bidders should follow this time during bid submission.
- 7) The documents being submitted by the bidders would be encrypted using PKI encryption all techniques to ensure the secrecy of the data. The data entered cannot be viewed by unauthorized persons until the time of bid opening. The confidentiality of the bids is maintained using the secured Socket Layer 128 bit encryption technology. Data storage encryption of sensitive fields is done. Any bid document that is uploaded to the server is subjected to symmetric encryption using a system generated symmetric key.
- 8) Further this key is subjected to asymmetric encryption using buyers/bid opener’s public keys. Overall, the uploaded tender documents become readable only after the tender opening by the authorized bid openers.
- 9) The uploaded tender documents become readable only after the tender opening by the authorized bid openers.

- 10) Upon the successful and timely submission of bids (ie after Clicking "Freeze Bid Submission" in the portal), the portal will give a successful bid submission message & a bid summary will be displayed with the bid no. and the date & time of submission of the bid with all other relevant details.
- 11) The bid summary has to be printed and kept as an acknowledgement of the submission of the bid. This acknowledgement may be used as an entry pass for any bid opening meetings.

**ASSISTANCE TO BIDDERS**

- 1) Any queries relating to the tender document and the terms and conditions contained therein should be addressed to the Tender Inviting Authority for a tender or the relevant contact person indicated in the tender.
- 2) Any queries relating to the process of online bid submission or queries relating to CPP Portal in general may be directed to the 24x7 CPP Portal Helpdesk number 0120-4200462, 0120-4001002.