



आरोग्यम् सुख सम्पदा

ALL INDIA INSTITUTE OF MEDICAL SCIENCES, RAIPUR

OFFICE OF
THE EXECUTIVE ENGINEER
PROJECT CELL AIIMS, RAIPUR

NOTICE INVITING e-TENDER

N.I.T. NO. 66/EE/AIIMS/RPR/2020-21

NAME OF WORK: -“**Augmentation of Existing Electrical Distribution system for Phase- 1 (In Substation- 2, 3, 4 and Hospital Block) at AIIMS Raipur.**”

ESTIMATED COST: Rs 2,29,97,589.00/-

EARNEST MONEY: EMD Declaration Form (As Per Annexure-H)

CONTRACT PERIOD: 240 Days

Type of work: Maintenance work

e-sign by Manoj Rastogi
Executive Engineer (Civil)
AIIMS, Raipur

INDEX

Name of Work: -“**Augmentation of Existing Electrical Distribution system for Phase- 1
(In Substation- 2, 3, 4 and Hospital Block) at AIIMS Raipur.**”

Sl. No	Particulars	Page No.	
		From	To
1	COVER PAGE	1	1
2	INDEX	2	2
3	INSTRUCTIONS FOR ONLINE BID SUBMISSION	3	5
4	NOTICE INVITING E-TENDER	6	6
5	INFORMATION AND INSTRUCTIONS FOR BIDDERS FOR E-TENDERING	7	11
6	LIST OF MANDATORY DOCUMENTS TO BE FILLED IN BY THE BIDDERS IN VARIOUS FORMS TO BE SCANNED AND UPLOADED WITHIN THE PERIOD OF BID SUBMISSION	12	12
7	LETTER OF TRANSMITTAL(ANNEXURE-A)	13	13
8	FORM FOR DETAILED INFORMATION BY BIDDER (VENDOR DETAILS) (ANNEXURE-B)	14	14
9	STRUCTURE & ORGANISATION (ANNEXURE-C)	15	15
10	DECLARATION(ANNEXURE-D)	16	16
11	INTEGRITY PACT(ANNEXURE-E)	17	17
12	ACKNOWLEDGEMENT & ACCEPTANCE LETTER(ANNEXURE-F)	18	18
13	CONSENT LETTER(ANNEXURE-G)	19	19
14	EMD DECLARATION FORM (ANNEXURE-H)	20	20
15	INTEGRITY AGREEMENT	21	25
16	ITEM RATE TENDER & CONTRACT FOR WORKS	26	27
17	GENERAL PARTICULAR & ADDITIONAL CONDITIONS OF CONTRACT	28	31
18	SCOPE OF WORK AND TECHNICAL SPECIFICATIONS FOR ELECTRICAL WORKS	32	43
19	FORM OF EARNEST MONEY DEPOSIT (BANK GUARANTEE BOND)ANNEXURE-I	44	44
20	FORM OF PERFORMANCE GUARANTEE BANK GUARANTEE	45	46
21	SPECIAL CONDITIONS OF CONTRACT	47	53
22	FORM OF APPLICATION BY THE CONTRACTOR FOR SEEKING EXTENSION OF TIME (PART I)	54	54
23	FORM OF APPLICATION OF THE CONTRACTOR FOR SEEKING RESCHEDULING OF THE MILESTONES	55	55
24	GUARANTEE BOND TO BE EXECUTED BY CONTRACTORS FOR REMOVAL OF DEFECTS AFTER COMPLETION IN RESPECT OF WATER PROOFING WORKS	56	56
25	LIST OF SPECIALIZED ITEMS / JOBS	57	60
26	NO CLAIM CERTIFICATE (ON COMPANY LETTERHEAD)	61	61
27	APPROVED MATERIALS LIST (ELECTRICAL)	62	63
28	PROFORMA OF SCHEDULES (A TO H)	64	68
29	ELECTRICAL PANEL DRAWING	69	73

INSTRUCTIONS FOR ONLINE BID SUBMISSION

The bidders are required to submit soft copies of their bids electronically on the CPP Portal, using valid Digital Signature Certificates. The instructions given below are meant to assist the bidders in registering on the CPP Portal, prepare their bids in accordance with the requirements and submitting their bids online on the CPP Portal.

More information useful for submitting online bids on the CPP Portal may be obtained at: **<https://eprocure.gov.in/eprocure/app>**.

REGISTRATION:

- 1) Bidders are required to enrol on the e-Procurement module of the Central Public Procurement Portal (URL: <https://eprocure.gov.in/eprocure/app>) by clicking on the link "Online bidder Enrolment" on the CPP Portal which is free of charge.
- 2) As part of the enrolment process, the bidders will be required to choose a unique username and assign a password for their accounts.
- 3) Bidders are advised to register their valid email address and mobile numbers as part of the registration process. These would be used for any communication from the CPP Portal.
- 4) Upon enrolment, the bidders will be required to register their valid Digital Signature Certificate (Class II or Class III Certificates with signing key usage) issued by any Certifying Authority recognized by CCA India (e.g. Sify/nCode /eMudhra etc.), with their profile.
- 5) Only one valid DSC should be registered by a bidder. Please note that the bidders are responsible to ensure that they do not lend their DSC's to others which may lead to misuse.
- 6) Bidder then logs in to the site through the secured log-in by entering their user ID / password and the password of the DSC / e-Token.

SEARCHING FOR TENDER DOCUMENTS:

- 1) There are various search options built in the CPP Portal, to facilitate bidders to search active tenders by several parameters. These parameters could include Tender ID, Organization Name, Location, Date, Value, etc. There is also an option of advanced search for tenders, wherein the bidders may combine a number of search parameters such as Organization Name, Form of Contract, Location, Date, Other keywords etc. to search for a tender published on the CPP Portal.
- 2) Once the bidders have selected the tenders they are interested in, they may download the required documents / tender schedules. These tenders can be moved to the respective 'My Tenders' folder. This would enable the CPP Portal to intimate the bidders through SMS / e-mail in case there is any corrigendum issued to the tender document.
- 3) The bidder should make a note of the unique Tender ID assigned to each tender, in case they want to obtain any clarification / help from the Helpdesk.

PREPARATION OF BIDS:

- 1) Bidder should take into account any corrigendum published on the tender document before submitting their bids.

- 2) Please go through the tender advertisement and the tender document carefully to understand the documents required to be submitted as part of the bid. Please note the Number of covers in which the bid documents have to be submitted, the number of documents - including the names and content of each of the document that need to be submitted. Any deviations from these may lead to rejection of the bid.
- 3) Bidder, in advance, should get ready the bid documents to be submitted as indicated in the tender document / schedule and generally, they can be in PDF / XLS / RAR / DWF/JPG formats. Bid documents may be scanned with 100 dpi with black and white option which helps in reducing size of the scanned document.
- 4) To avoid the time and effort required in uploading the same set of standard documents which are required to be submitted as a part of every bid, a provision of uploading such standard documents (e.g. PAN card copy, annual reports, auditor certificates etc.) has been provided to the bidders. Bidders can use “My Space” or “Other Important Documents” area available to them to upload such documents. These documents may be directly submitted from the “My Space” area while submitting a bid, and need not be uploaded again and again. This will lead to a reduction in the time required for bid submission process.

SUBMISSION OF BIDS:

- 1) Bidder should log into the site well in advance for bid submission so that they can upload the bid in time i.e. on or before the bid submission time. Bidder will be responsible for any delay due to other issues.
- 2) The bidder has to digitally sign and upload the required bid documents one by one as indicated in the tender document.
- 3) Bidder has to select the payment option as “offline” to pay the tender fee / ~~EMD~~ as applicable and enter details of the instrument.
- 4) Bidder should prepare the ~~EMD~~ as per the instructions specified in the tender document. The original should be posted/couriered/given in person to the concerned official, latest by the last date of bid submission or as specified in the tender documents. The details of the DD/any other accepted instrument, physically sent, should tally with the details available in the scanned copy and the data entered during bid submission time. Otherwise the uploaded bid will be rejected.
- 5) Bidders are requested to note that they should necessarily submit their financial bids in the format provided and no other format is acceptable. If the price bid has been given as a standard BoQ format with the tender document, then the same is to be downloaded and to be filled by all the bidders. Bidders are required to download the BoQ file, open it and complete the white coloured (unprotected) cells with their respective financial quotes and other details (such as name of the bidder). No other cells should be changed. Once the details have been completed, the bidder should save it and submit it online, without changing the filename. If the BoQ file is found to be modified by the bidder, the bid will be rejected.
- 7) The server time (which is displayed on the bidders’ dashboard) will be considered as the standard time for referencing the deadlines for submission of the bids by the bidders, opening of bids etc. The bidders should follow this time during bid submission.
- 8) The documents being submitted by the bidders would be encrypted using PKI encryption all techniques to ensure the secrecy of the data. The data entered cannot be viewed by unauthorized persons until the time of bid opening. The confidentiality of the bids is maintained using the secured Socket Layer 128-bit encryption technology. Data storage

encryption of sensitive fields is done. Any bid document that is uploaded to the server is subjected to symmetric encryption using a system generated symmetric key.

- 9) Further this key is subjected to asymmetric encryption using buyers/bid opener's public keys. Overall, the uploaded tender documents become readable only after the tender opening by the authorized bid openers.
- 10) The uploaded tender documents become readable only after the tender opening by the authorized bid openers.
- 11) Upon the successful and timely submission of bids (i.e. after Clicking "Freeze Bid Submission" in the portal), the portal will give a successful bid submission message & a bid summary will be displayed with the bid no. and the date & time of submission of the bid with all other relevant details.
- 12) The bid summary has to be printed and kept as an acknowledgement of the submission of the bid. This acknowledgement may be used as an entry pass for any bid opening meetings.

ASSISTANCE TO BIDDERS:

- 1) Any queries relating to the tender document and the terms and conditions contained therein should be addressed to the Tender Inviting Authority for a tender or the relevant contact person indicated in the tender.
- 2) Any queries relating to the process of online bid submission or queries relating to CPP Portal in general may be directed to the 24x7 CPP Portal Helpdesk number 0120-4200462, 0120-4001002.
- 3) For any further assistance, please contact to the office of Executive Engineer, AIIMS Raipur.

ALL INDIA INSTITUTE OF MEDICAL SCIENCES, RAIPUR

NOTICE INVITING e-TENDER

(a)	Name of Work	“Augmentation of Existing Electrical Distribution system for Phase- 1 (In Substation- 2, 3, 4 and Hospital Block) at AIIMS Raipur”
(b)	Tender No.	66/EE/AIIMS/RPR/2020-21
(c)	Contract Period	240 days
(d)	Estimated Cost	Rs 2,29,97,589.00
(e)	Earnest Money Deposit (Mandatory to submit original EMD for participating in bid & no need to submit whole tender hardcopy documents.)	EMD Declaration Form (As Per Annexure-H)
(f)	Performance Guarantee	3% of Tendered value.
(g)	Security Deposit	2.5% of the Tendered Value.
(h)	Tender documents may be seen on	AIIMS web site www.aiimsraipur.edu.in and CPPP site https://eprocure.gov.in/eprocure/app
(j)	Last Date & Time of Submission	By 26/02/2021 UP TO 11:00 Hours through online.
(k)	Date & Time for opening of Technical Bid	On 27/02/2021 at 11:30 Hours.

1. The indenting Bidder must read the Terms & conditions carefully. He/ She should only submit bid if consider himself/herself eligible and bidder in possession of all the documents required.
2. Information and Instructions for bidders posted on website shall form part of bid document.
3. The Bid documents consisting of specifications, the schedule of quantities of various types of items to be executed and the set of terms & conditions of the contract to be complied with and other necessary documents can be seen and downloaded from website www.aiimsraipur.edu.in Or <https://eprocure.gov.in/eprocure/app>.
4. For any further assistance, please contact to the office of Executive Engineer, AIIMS Raipur or mail to tenderprojectcell@aiimsraipur.edu.in / ee.civil@aiimsraipur.edu.in .

e-sign by Manoj Rastogy
Executive Engineer (Civil)
AIIMS, Raipur

INFORMATION AND INSTRUCTIONS FOR BIDDERS FOR e TENDERING

The Executive Engineer (Civil), AIIMS, Raipur on behalf of Director, AIIMS, Raipur invites online **Item Rate bids in Two bid system** (Technical cum Eligibility & Financial) from eligible and registered contractors of appropriate list of CPWD , M.E.S., BSNL, Railway, PSU's, P.W.D. (B&R), Chhattisgarh State Electricity Board and specialized agency for the following work(s):-

Sl. No.	Description	Details
(a)	NIT No.	66/EE/AIIMS/RPR/2020-21
(b)	Name of Work:	“Augmentation of Existing Electrical Distribution system for Phase- 1 (In Substation- 2, 3, 4 and Hospital Block) at AIIMS Raipur.”
(c)	Estimated Cost	Rs 2,29,97,589.00
(d)	Earnest Money Deposit (Mandatory to submit original EMD for participating in bid & no need to submit whole tender hardcopy documents.)	EMD Declaration Form (As Per Annexure-H)
(e)	Period of Completion	240 days
(f)	Last Date & Time of Submission	By 26/02/2021 UP TO 11:00 Hours through online.
(g)	Date & Time for opening of Technical Bid	On 27/02/2021 at 11:30 Hours.

1. The intending bidder must read the terms and conditions of Tender document carefully. Bidder may submit bid having all required documents.
2. Intending bidders shall have to register at CPPP portal to participate in the tendering process. For details kindly visit website [http:// eprocure.gov.in/eprocure/app](http://eprocure.gov.in/eprocure/app) or In case the bidder requires any elucidation regarding the tender documents, may contact to the office of Project Cell, AIIMS Raipur before the opening of tender date.
3. For e-tendering of this tender, downloaded from AIIMS Raipur website and Central Public Procurement Portal (CPPP) e-Procurement website.
4. The intending bidders must have valid class-III digital signature to submit the bid. **Manual bid shall not be accepted in any circumstance.** The complete bidding process is online bidding; Bidder should have valid digital Signature Certificate (DSC) for online submission of bids.
5. The bid document consisting of plans, specifications, the schedule of quantities of various types of items to be executed and the set of terms and conditions of the contract to be complied with and other necessary documents can be seen and downloaded from website [http:// eprocure.gov.in/eprocure/app](http://eprocure.gov.in/eprocure/app) free of cost.
6. The bid can be submitted only after uploading the mandatory scanned documents up to 100 dpi Copies of eligibility documents and ~~EMD~~ as specified on the e-tendering website within

the period of tender submission. Bidders can upload documents in the form of JPG format, PDF format and any other format as permissible by the e-tendering portal.

7. Bidders must ensure to quote rate of each item. If any cell is left blank the same shall be treated as "0". Therefore, If any cell is left blank and no rate is quoted by the bidder, rate of such item shall be treated as "0" (ZERO). After submission of the bid online the contractor can re-submit revised bid any number of times but before last time and date of submission of bid as notified.
8. After submission of bid online, it can be revised any number of times before specified time on last date of submission of bid. While submitting the revised bid, bidder can revise the rate of one or more item(s) any number of times (need not re-enter rate of all the items) but before last time and date of submission of bid as notified.
9. Financial bids shall be opened online only for bidders for whom EMD and other uploaded documents are found in order and who are found to be eligible to bid for work. On opening date, the bidder can log in and see the bid opening process. After opening of bid he/she will receive the competitor bid sheets.
10. If the bidder is found ineligible after opening of technical cum eligibility, bid shall become invalid.
11. ~~The Bidders shall have to submit original instrument for EMD (EMD released of any work will not be accepted again if earlier submitted in any case) before the last date of opening of TECHNICAL Cum Eligibility Bid to the office of Tender Opening Authority. The bid security is to remain valid for a period of 45 (forty-five) days beyond the final bid validity period. Bid security will be refunded to the successful bidder on receipt of a performance security. Bid securities of the unsuccessful bidders should be returned at the earliest after L1 decided by Committee of AIIMS Raipur.~~
12. The Technical cum Eligibility bid shall be opened first on due date and time as mentioned above. Opening of financial bids of contractors qualifying the eligibility shall be opened at a later date.
13. The department reserves the right to reject any prospective application without assigning any reason and to restrict the list of qualified contractors to any number deemed suitable by it, if too many bids are received satisfying the laid down criteria.
14. **Performance Guarantee:** The successful contractor will be required to furnish a Performance guarantee of **3% (Three Percentage)** of Tendered Value after receiving notification of award in the form of **an account payee demand draft, fixed deposit receipt from a commercial bank, bank guarantee issued/ confirmed from any of the commercial bank in India** in the name of the "All India Institute of Medical Sciences, Raipur" which shall be kept valid for a period of Six (06) months beyond completion of all the contractual obligations. The Performance Guarantee can be forfeited in the event of any breach or negligence or non-observance of any condition of contract or for unsatisfactory performance or non-observance of any condition of the contract. Performance Security will be released after successful completion of work under the contract. In case the contractor fails to deposit the said performance guarantee within the period including the extended period if any, ~~the Earnest Money deposited by the contractor shall be forfeited automatically without any notice to the contractor. The earnest money deposited along with tender shall be returned after receiving the aforesaid performance guarantee.~~
15. **Sources and Verification of Bank Guarantees**
Bank Guarantee for ~~Bid Security (EMD)~~ or Performance Guarantee (Security Deposit) should be irrevocable and operative Bank Guarantee (BG) as per format enclosed in the Bid Document and should be issued by a Scheduled Commercial (i.e. Indian or Foreign Banks included in the Second Schedule of Reserve Bank of India Act, 1934 excluding Co-operative banks or Regional Rural Banks). In case of foreign bidders or in case of GTE, if Bank Guarantee is from a foreign bank branch situated outside India, the Bank Guarantee must

be issued through any of the Scheduled Commercial Bank. In case BG is issued directly by a bank outside India, it should be executed on letter Head of the Bank and should be advised and made payable through their Indian Branch/Corresponding Bank in India. The Issuing Bank should also state the name and designation of the next Higher Authority of the Officials who have issued the Bank Guarantee. Bank guarantees submitted by the tenderers/~~contractors as EMD~~/ performance securities need to be immediately verified from the issuing bank **before acceptance**. There may not be any need to get the Bank Guarantee vetted from legal/ finance authority if it is in the specified format. Guidelines for verification of BGs submitted by the bidders/ ~~contractors against EMD~~/ performance security/ advance payments and for various other purposes are as follows:

- i) BG shall be as per the prescribed formats;
- ii) The BG contains the name, designation and code number of the Bank officer(s) signing the guarantee(s);
- iii) The address and other details (including telephone no.) of the controlling officer of the bank are obtained from the branch of the bank issuing the BG (this should be included in all BGs). The confirmation from the issuing branch of the bank is obtained in writing though registered post/ speed post/ courier. The bank should be advised to confirm the issuance of the BGs specifically quoting the letter of Procurement Entity on the printed official letterhead of the bank indicating address and other details (including telephone nos.) of the bank and the name, designation and code number of the officer(s) confirming the issuance of the BG; Pending receipt of confirmation as above, confirmation can also be obtained with the help of responsible officer at the field office, which is close to the issuing branch of the bank, who should personally obtain the confirmation from issuing branch of the bank and forward the confirmation report to the concerned procurement entity.

16. Intending Bidders are advised to inspect and examine the site and its surroundings and satisfy themselves before submitting their bids, the means of access to the site, the accommodation they may require and in general shall themselves obtain all necessary information as to risks, contingencies and other circumstances which may influence or affect their bid. A bidder shall be deemed to have full knowledge of the site whether he inspects it or not and no extra charge consequent on any misunderstanding or otherwise shall be allowed. The bidders shall be responsible for arranging and maintaining at his own cost, all materials, tools & plants, water, electricity access, facilities for workers and all other services required for executing the work unless otherwise specifically provided for in the contract documents. Submission of a bid by a bidder implies that he has read this notice and all other contract documents and has made himself aware of the scope and specifications of the work to be done and of conditions.
17. The Tender paper/documents can be seen / downloaded from Official website & submitted through Online or Site.
18. The competent authority on behalf of the Director, AIIMS, Raipur does not bind itself to accept the lowest or any other bid and reserves to itself the authority to reject any or all the bids received without the assignment of any reason. All bids in which any of the prescribed condition is not fulfilled or any condition including that of conditional rebate is put forth by the bidder shall be summarily rejected.
19. Canvassing whether directly or indirectly, in connection with bidders is strictly prohibited and the bids submitted by the contractors who resort to canvassing will be liable to rejection.
20. The Competent Authority, The **Engineer-In-Charge**, reserves to himself the right of accepting the whole or any part of the bid and the bidder shall be bound to perform the same at the rate quoted.
21. The contractor shall not be permitted to bid for works in the AIIMS, Raipur responsible for award and execution of contracts, in which his near relative is posted as an officer in

any capacity between the grades of Superintending Engineer and Junior Engineer (both inclusive). He shall also intimate the names of persons who are working with him in any capacity or are subsequently employed by him and who are near relatives to any gazetted officer in the AIIMS, Raipur. Any breach of this condition by the contractor would render him liable to be removed from the approved list of contractors of this Department.

22. The bid for the works shall remain open for acceptance for a period of **90 days** from the date of opening of technical bids.

23. This notice inviting bid shall form a part of the contract document. The successful bidder/ contractor, on acceptance of his bid by the Accepting Authority shall within 15 days from the stipulated date of start of the work, sign the contract consisting of "The Notice Inviting bid, all the documents including additional conditions, specifications and drawings, GCC, if any, forming part of the bid as uploaded at the time of invitation of bid and rate quoted online at the time of submission of bid and acceptance thereof together with any correspondence leading thereto.

24. Eligibility of Bidder

"The Similar work means providing "Supply Installation testing and commissioning of LT/HT panels in Electrical substation."

- (a) Three similar works, each of value not less than 40% or Two similar works each of value not less than 60% or one similar work of 80% of estimated cost put to tender in last 07 (Seven) Years up to the date of receipt of tender. The value of executed works shall be brought to current costing level by enhancing the actual value of work at simple rate of 07% per annum, calculated from the date of completion to the last date of receipt of tender.
- (b) The Bidder should have registration with Employee Provident Fund (EPF) Commissioner and Employee State Insurance (ESI) Corporation.
- (c) The experience of similar work should be from Central Govt., State Govt., PSU and Autonomous Body.
- (d) Conditional Bids shall not be considered and will be out-rightly rejected at the very first instance.
- (e) All eligible bidders meeting the eligibility can participate in the tender. The applicant should be a private or government-owned legal entity;
- (f) For package size exceeding certain values [say - Rs. 10 (ten) Crore], Joint Ventures may be allowed. Maximum number of partners in Joint Ventures shall be limited (say – three). In case of Joint Ventures, all the partners shall be jointly and severally liable for the successful completion of the work;
- (g) A firm that has been engaged by Ministry/ Department to provide consultancy services for the preparation or implementation of a project, and any of its affiliates (associates, Subsidiary, Joint Ventures partner), shall not be eligible for subsequently providing goods or works (other than a continuation of the firm's earlier consultancy services) for the same project;
- (h) A firm determined non-performing by the Procuring Entity shall not be eligible to bid during the period so determined;
- (i) The bidder must not have in his employment:
 - a) The near relations (defined as first blood relations, and their spouses, of the bidder or the bidder's spouse) of persons involved in decision making in the procurement.
 - b) Without Government permission, any person who retired as gazetted officer within the last two years of the rank and from the departments.
- (j) Valid Goods and services Tax (GST)

25. Signing of bid document :

- a)** If the bidder is an individual, the bid shall be signed by him above his full type written name and current address.
- b)** If the bidder is a proprietary firm, the bid shall be signed by the proprietor above his full type written name and the full name of his firm with its current address.
- c)** If the bidder is a firm in partnership, the bid shall be signed by all the partners of the firm above their full type written names and current addresses, or, alternatively, by a partner holding power of attorney for the firm. In the later case a certified copy of the power of attorney should accompany the application. In both cases a certified copy of the partnership deed and current address of all the partners of the firm should accompany the application.
- d)** If the bidder is a limited company or a corporation, the bid shall be signed by a duly authorized person holding power of attorney for signing the application accompanied by a copy of the power of attorney. The bidder should also furnish a copy of the Memorandum of Articles of Association duly attested by a Public Notary.

26. In the bid documents the word / sentence shall be read as under :-

- (i) President of India – Director, AIIMS, Raipur
- (ii) The terms Director General includes CPM/ADG region/ SDG PR Special Director General / Additional Director General and CPM/ Chief Engineer of the Zone - The terms Director General includes Director/Superintending Engineer/Executive Engineer, AIIMS, Raipur.
- (iii) CPWD – AIIMS, Raipur or vice versa.

27. Any dispute or difference arising out of this contract or in connection therewith which cannot be amicably settled between the parties shall be finally settled under the rules of council of Arbitration of India by one or more arbitrator appointed in accordance with the said rules. The arbitration shall take place at Raipur (Chhattisgarh) and the resulting award shall be final and binding upon the parties and shall be in lieu of any other remedy.

List of Mandatory Documents to be filled in by the bidders in various forms to be scanned and uploaded within the period of bid submission

1	EMD in the form of an account payee demand draft, fixed deposit receipt from a commercial bank, bank guarantee issued/ confirmed from any of the commercial bank in India in the name of the "All India Institute of Medical Sciences, Raipur"
2	Enlistment Order for the Contractor
3	Letter of transmittal (Annexure-A)
4	Vendor Details as per (Annexure-B)
5	Structure & Organization (Annexure-C)
6	Declaration by Bidder (Annexure-D)
7	Acknowledgement & Acceptance Letter (Annexure-F)
8	Consent Letter(Annexure-G)
9	EMD Declaration Form (Annexure-H)
10	Valid GST Registration Certificate
11	Registration Certificate of EPFO & ESIC
12	Experience certificate duly issued by the Government/Semi Government/state Govt./Central/any autonomous body/ PSU's not below the rank of Executive Engineer or tender inviting authority (REFER ELIGIBILITY CRITERIA PAGE NO-10)

e-sign by Manoj Rastogi
Executive Engineer (Civil)
AIIMS, Raipur

LETTER OF TRANSMITTAL

From:

To

The Executive Engineer,

Project Cell, AIIMS, Raipur (C.G.)

Subject: Submission of bids for the work of Augmentation of Existing Electrical Distribution system for Phase- 1 (In Substation- 2, 3, 4 and Hospital Block) at AIIMS Raipur.

Sir,

Having examined the details given in the bid document for the above work, I/we hereby submit the relevant information.

1. I/we hereby certify that all the statement made and information supplied in the enclosed forms A to G (except E) and accompanying statement are true and correct.
2. I/we have furnished all information and details necessary for eligibility and have no further pertinent information to supply.
3. I/we authorize Engineer-In-Charge or his representative to approach individuals, employers, firms and corporation to verify our competence and general reputation.

Certificate: It is certified that the information given in the enclosed eligibility bid are correct. It is also certified that I / We shall be liable to be debarred, disqualified / cancellation of enlistment in case any information furnished by me / us is found to be incorrect.

Enclosures:

Date of submission:

Signature(s) of Bidder(s)
Seal of bidder

FORM FOR DETAILED INFORMATION BY BIDDER (Vendor Details)

1.	Name of the Bidder	
2.	Permanent Account No (PAN)	
3.	Particulars of Bank Account	
	a) Name of the Bank	
	b) Name of the Branch	
	c) Branch Code	
	d) Address	
	e) City Name	
	f) Telephone No	
4.	Legal status of the bidder (attach copies of original document defining the legal status)	
	a) An Individual	
	b) A proprietary firm	
	c) A firm in partnership	
	d) A limited company or Corporation	
5.	GST Registration Certificate No	
6.	Valid Email ID of the Bidder	
7.	Complete Postal Address of the bidder	

(Authorized Signature of the Bidder with Seal)

STRUCTURE & ORGANISATION

1. (a) Name
(b) Address of the bidder
2. (a) Telephone no.
(b) Telex no.
(c) Fax no.
(d) E-mail
3. Legal status of the bidder (attach copies of original document defining the legal status)
 - (a) An Individual
 - (b) A proprietary firm
 - (c) A firm in partnership
 - (d) A limited company or Corporation
4. Particulars of registration with various Government Bodies if any (attach attested photocopy)

Organization/Place of registration	Registration No.
1.	
2.	
3.	
5. Names and titles of Directors & Officers with designation to be concerned with this work.

Signature of Bidder(s)

DECLARATION

It is to certify that:

- 1) I/We agree with the terms and conditions of it and understood that it will form part of the agreement.
- 2) I hereby certify that none of my Relative(s) are employed in AIIMS Raipur, Chhattisgarh. In case at any stage, it is found that the information given by me is false/incorrect, AIIMS shall have the absolute right to take any action as deemed fit without any prior intimation to me”.
- 3) I/We undertake and confirm that eligible Work(s) has/have not been got executed through another contractor on back to back basis. Further, it is stated that, if such a violation comes to the notice of Department, than I/We shall be debarred for bidding in AIIMS in future forever. Also, if such a violation comes to the notice of AIIMS, Raipur before date of start of work, the Engineer-In-Charge shall be free to forfeit the entire amount of ~~Earnest Money Deposit~~/Performance Guarantee.
- 4) I / We have signed (with stamp) uploaded documents of the tender before submitting the same.
- 5) All the information and documents given/ uploaded for bids are true.
- 6) I / We have submitted the EMD Declaration Form (As per Annexure-H).
- 7) I / We have provided our e-Mail id for any communication in this regard.
- 8) I have read carefully & understood the important instructions to the all bidders.

Date.....

Contractor

E-Mail: _____

(Sign with Seal)

INTEGRITY PACT

To,

Sub: NIT No. **66/EE/AIIMS/RPR/2020-21 for the work of “Augmentation of Existing Electrical Distribution system for Phase- 1 (In Substation- 2, 3, 4 and Hospital Block) at AIIMS Raipur.”**

Dear Sir,

It is here by declared that AIIMS is committed to follow the principle of transparency, equity and competitiveness in public procurement.

The subject Notice Inviting Tender (NIT) is an invitation to offer made on the condition that the Bidder will sign the integrity Agreement, which is an integral part of tender / bid documents, failing which the tenderer / bidder will stand disqualified from the tendering process and the bid of the bidder would be summarily rejected.

This declaration shall form part and parcel of the Integrity Agreement and signing of the same shall be deemed as acceptance and signing of the Integrity Agreement on behalf of the AIIMS Raipur.

Yours faithfully,

e-sign by Manoj Rastogi
Executive Engineer (Civil)
AIIMS, Raipur

ACKNOWLEDGEMENT & ACCEPTANCE LETTER

To,

The Executive Engineer,

Project Cell, AIIMS Raipur

Sub: Submission of Tender for the work “**Augmentation of Existing Electrical Distribution system for Phase- 1 (In Substation- 2, 3, 4 and Hospital Block) at AIIMS Raipur.**”

Dear Sir,

I / We acknowledge that AIIMS is committed to follow the principles thereof as enumerated in the Integrity Agreement enclosed with the tender/bid document.

I / We agree that the Notice Inviting e-Tender is an invitation to offer made on the condition that I/We will sign the enclosed integrity Agreement, which is an integral part of tender documents, failing which I/We will stand disqualified from the tendering process. I/We acknowledge that THE MAKING OF THE BID SHALL BE REGARDED AS AN UNCONDITIONAL AND ABSOLUTE ACCEPTANCE of this condition of the NIT.

I/We confirm acceptance and compliance with the Integrity Agreement in letter and spirit and further agree that execution of the said Integrity Agreement shall be separate and distinct from the main contract, which will come into existence when tender/bid is finally accepted by AIIMS Raipur. I/We acknowledge and accept the duration of the Integrity Agreement, which shall be in the line with Article 1 of the enclosed Integrity Agreement.

I/We acknowledge that in the event of my/our failure to sign and accept the Integrity Agreement, while submitting the tender/bid, AIIMS Raipur shall have unqualified, absolute and unfettered right to disqualify the tenderer/bidder and reject the tender/bid in accordance with terms and conditions of the tender/bid.

Yours Faithfully

(Duly authorized signatory of the Bidder)

CONSENT LETTER

I/We hereby give my/ our consent to work as contractor till the completion of work and I/we will be responsible for execution of work only by skilled persons in the field of **related work** as per satisfaction of Engineer-In-Charge.

I/We will produce computerized measurement sheets of work before covering hidden work / job and other exposed works in time as per **clause 6** otherwise measurement will be recorded by the representative of Engineer-In-Charge which will be bound to me and I/We am/are agree to made recovery of amount as per **clause 32** of GCC for each running and final bill for not producing measurement and bill. Final measurement with bill will be produced by me/us within one month after completion date otherwise representative of Engineer-In-Charge will prepare the same which will be acceptable and bound to me/us and no any claim in this regard will be made by me/us.

I/We will provide all invoices and related test certificates of materials as required by E-In-C. All Analysis of rates for Extra, Substitute, Deviation items etc. will be produced by me/us in consultation with representative of Engineer-In- Charge on time for getting approval from Competent Authority of AIIMS before execution of work or otherwise the same will be prepared by the department and will be bound to me/us.

I/We will maintain all the registers etc. as mentioned in General Condition of Contract for workers and employees. The registers will be presented to Engineer In-charge or his authorized representative for verification from time to time.

I/we will also engage suitable and skill Engineer(s) for the work as per condition of work.

I further certify that the above particulars pertaining to me are correct.

I/We will produce all uploaded documents in original for physical verification before issue of Letter of Acceptance or / and as demanded by Engineer-In Charge before the payment.

I/We will submit "No Claim Certificate" in the approved format in company letter head after receiving final bill payment.

Signature of contractor

EMD Declaration Form

Date:

To,

Executive Engineer,

All India Institute of Medical Sciences Raipur (C.G)

Ref: **66/EE/AIIMS/RPR/2020-21.**

Dear Sir,

I/we accept that I/We may be disqualified/debarred from bidding for any contract with you for a period of one year from the date of notification, if I am /We are in a breach of any obligation under the bid conditions, because

I/We

- a) have withdrawn/modified/amended from the tender, my/our Bid during the period of bid validity specified in the NIT; or
- b) having been notified of the acceptance of our Bid by the purchaser during the period of bid validity.

i. fail or reuse to execute the contract, if required, or

ii. fail or refuse to furnish the Performance Security, in accordance with the Instructions to Bidders

The validity of this declaration will remain till the announcement of the name of the successful Bidder & if, I

am/we are not the successful Bidder.

Yours faithfully,

(Signature of Bidder with seal)

Place:

To be signed by the bidder and same signatory competent / authorized to sign the relevant contract on behalf of AIIMS Raipur.

INTEGRITY AGREEMENT

This Integrity Agreement is made at on this day of 2019

BETWEEN

AIIMS Raipur through Executive Engineer,....., (Name of Division)
AIIMS, , (Hereinafter referred as the
(Address of Division)

'Principal / Owner', which expression shall unless repugnant to the meaning or context hereof include its successors and permitted assigns)

AND

(Name and Address of the Individual/firm/Company)
through (hereinafter referred to as the
(Details of duly authorized signatory)

“Bidder/Contractor” and which expression shall unless repugnant to the meaning or context hereof include its successors and permitted assigns)

Preamble

WHEREAS the Principal /Owner has floated the e-Tender (**NIT No.66/EE/AIIMS/RPR/2020-21**) (hereinafter referred to as “**Tender/Bid**”) and intends to award, under laid down organizational procedure, contract for “**Augmentation of Existing Electrical Distribution system for Phase- 1 (In Substation- 2, 3, 4 and Hospital Block) at AIIMS Raipur.**” Here in after referred to as the “**Contract**”.

AND WHEREAS the Principal / Owner values full compliance with all relevant laws of the land, rules, regulations, economic use of resources and of fairness/transparency in its relation with its Bidder(s) and Contractor(s).

AND WHEREAS to meet the purpose aforesaid both the parties have agreed to enter into this Integrity Agreement (hereinafter referred to as “**Integrity Pact**” or “**Pact**”), the terms and conditions of which shall also be read as integral part and parcel of the Tender/Bid documents and Contract between the parties.

NOW, THEREFORE, in consideration of mutual covenants contained in this Pact, the parties hereby agree as follows and this Pact witnesses as under:

ARTICLE 1: COMMITMENT OF THE PRINCIPAL / OWNER

1. The Principal/Owner commits itself to take all measures necessary to prevent corruption and to observe the following principles:
 - (a) No employee of the Principal/Owner, personally or through any of his/her family members, will in connection with the Tender, or the execution of the Contract, demand, take a promise for or accept, for self or third person, any material or immaterial benefit which the person is not legally entitled to.
 - (b) The Principal/Owner will, during the Tender process, treat all Bidder(s) with equity and reason. The Principal/Owner will, in particular, before and during the Tender process, provide to all Bidder(s) the same information and will not provide to any Bidder(s) confidential / additional information through which the Bidder(s) could obtain an advantage in relation to the Tender process or the Contract execution.
 - (c) The Principal / Owner shall endeavor to exclude from the Tender process any person, whose conduct in the past has been of biased nature.
2. If the Principal/Owner obtains information on the conduct of any of its employees which is a criminal offence under the Indian Penal code (IPC) / Prevention of Corruption Act, 1988 (PC Act) or is in violation of the principles herein mentioned or if there be a substantive suspicion in this regard, the Principal / Owner will inform the Chief Vigilance Officer and in addition can also initiate disciplinary actions as per its internal laid down policies and procedures.

ARTICLE 2: COMMITMENT OF THE BIDDER (S) / CONTRACTOR (S)

- 1) It is required that each Bidder /Contractor (including their respective officers, employees and agents) adhere to the highest ethical standards, and report to the Government / Department all suspected acts of fraud or corruption or Coercion or Collusion of which it has knowledge or becomes aware, during the tendering process and throughout the negotiation or award of a contract.
- 2) The Bidder(s) / Contractor(s) commit himself to take all measures necessary to prevent corruption. He commits himself to observe the following principles during his participation in the Tender process and during the Contract execution:

- a) The Bidder(s) / Contractor(s) will not, directly or through any other person or firm, offer, promise or give to any of the Principal / Owner's employees involved in the Tender process or execution of the Contract or to any third person any material or other benefit which he/she is not legally entitled to, in order to obtain in exchange any advantage of any kind whatsoever during the Tender process or during the execution of the Contract.

The Bidder(s) / Contractor (s) will not enter with other Bidder (s) into any undisclosed agreement or understanding, whether formal or informal. This applies in particular to prices, specifications, certifications, subsidiary contracts, submission or non-submission of bids or any other actions to restrict competitiveness or to cartelize in the bidding process.

- b) The Bidder(s) / Contractor(s) will not commit any offence under the relevant IPC/PC Act. Further the Bidder(s) / Contractor(s) will not use improperly, (for the purpose of competition or personal gain), or pass on to others, any information or

documents provided by the Principal/Owner as part of the business relationship, regarding plans, technical proposals and business details, including information contained or transmitted electronically.

- c) The Bidder(s)/ Contractor(s) of foreign origin shall disclose the names and addresses of agents / representatives in India, if any. Similarly Bidder(s)/Contractor(s) of Indian Nationality shall disclose names and addresses of foreign agents/representatives, if any. Either the Indian agent on behalf of the foreign principal or the foreign principal directly could bid in a tender but not both. Further, in cases where an agent participate in a tender on behalf of one manufacturer, he shall not be allowed to quote on behalf of another manufacturer along with the first manufacturer in a subsequent/parallel tender for the same item.
 - d) The Bidder(s)/ Contractor(s) will, when presenting his bid, disclose (with each tender as per Performa enclosed) any and all payments he has made, is committed to or intends to make to agents, brokers or any other intermediaries in connection with the award of the Contract
- 3) The Bidder(s) / Contractor(s) will not instigate third persons to commit offences outlined above or be an accessory to such offences.
 - 4) The Bidder(s) / Contractor(s) will not, directly or through any other person or firm indulge in fraudulent practice means a willful misrepresentation or omission of facts or submission of fake / forged documents in order to induce public official to act in reliance thereof, with the purpose of obtaining unjust advantage by or causing damage to justified interest of others and/or to influence the procurement process to the detriment of the Government interests.
 - 5) The Bidder(s) / Contractor(s) will not, directly or through any other person or firm use Coercive Practices (means the act of obtaining something, compelling an action or influencing a decision through intimidation, threat or the use of force directly or indirectly, where potential or actual injury may befall upon a person, his / her reputation or property to influence their participation in the tendering process).

ARTICLE 3: CONSEQUENCES OF BREACH

Without prejudice to any rights that may be available to the Principal/Owner under law or the Contract or its established policies and laid down procedures, the Principal / Owner shall have the following rights in case of breach of this Integrity Pact by the Bidder(s)/Contractor(s) and the Bidder / Contractor accepts and undertakes to respect and uphold the Principal / Owner's absolute right:

- 1) If the Bidder (s) / Contractor(s), either before award or during execution of Contract has committed a transgression through a violation of Article 2 above
or
in any other form, such as to put his reliability or credibility in question, the Principal/Owner after giving 14 days notice to the contractor shall have powers
to
Disqualify the Bidder(s)/Contractor(s) from the Tender process or terminate / determine the Contract, if already executed or exclude the Bidder/Contractor
from
Future contract award processes. The imposition and duration of the exclusion will be determined by the severity of transgression and determined by the Principal / Owner. Such exclusion may be forever or for a limited period as decided by the Principal/Owner.

2) **Forfeiture of EMD / Performance Guarantee / Security Deposit:**

If the Principal/Owner has disqualified the Bidder(s) from the Tender process prior to the award of the Contract or terminated/determined the Contract or has accrued the right to terminate/determine the Contract according to Article 3(1), the Principal/Owner apart from exercising any legal rights that may have accrued to the Principal/Owner, may in its considered opinion forfeit the entire amount of ~~Earnest Money Deposit~~, Performance Guarantee and Security Deposit of the Bidder / Contractor.

3) **Criminal Liability:**

If the Principal/Owner obtains knowledge of conduct of a Bidder or Contractor, or of an employee or a representative or an associate of a Bidder or Contractor which constitutes corruption within the meaning of Indian Penal code (IPC)/Prevention of Corruption Act, or if the Principal/Owner has substantive suspicion in this regard, the Principal/Owner will inform the same to law enforcing agencies for further investigation.

ARTICLE 4: PREVIOUS TRANSGRESSION

- 1) The Bidder declares that no previous transgressions occurred in the last 5 years with any other Company in any country confirming to the anticorruption approach or with Central Government or State Government or any other Central/State Public Sector Enterprises in India that could justify his exclusion from the Tender process.
- 2) If the Bidder makes incorrect statement on this subject, he can be disqualified from the Tender process or action can be taken for banning of business dealings/ holding listing of the Bidder/Contractor as deemed fit by the Principal/ Owner.
- 3) If the Bidder/Contractor can prove that he has resorted / recouped the damage caused by him and has installed a suitable corruption prevention system, the Principal/Owner may, at its own discretion, revoke the exclusion prematurely.

ARTICLE 5: EQUAL TREATMENT OF ALL BIDDERS/CONTRACTORS/SUBCONTRACTORS

- 1) The Bidder(s) / Contractor(s) undertake(s) to demand from all subcontractors a commitment in conformity with this Integrity Pact. The Bidder / Contractor shall be responsible for any violation(s) of the principles laid down in this agreement/Pact by any of its Sub- contractors/sub-vendors.
- 2) The Principal / Owner will enter into Pacts on identical terms as this one with all Bidders and Contractors.
- 3) The Principal / Owner will disqualify Bidders, who do not submit, the duly signed Pact between the Principal/Owner and the bidder, along with the Tender or violate its provisions at any stage of the Tender process, from the Tender process.

ARTICLE 6- DURATION OF THE PACT

This Pact begins when both the parties have legally signed it. It expires for the Contractor / Vendor 12 months after the completion of work under the contract or till the continuation of defect liability period, whichever is more and for all other bidders, till the Contract has been awarded.

If any claim is made/lodged during the time, the same shall be binding and continue to be valid despite the lapse of this Pacts as specified above, unless it is discharged/determined by the Competent Authority, AIIMS Raipur.

ARTICLE 7- OTHER PROVISIONS

- 1) This Pact is subject to Indian Law, place of performance and jurisdiction is the **Headquarters of the Division** of the Principal / Owner, who has floated the Tender.
- 2) Changes and supplements need to be made in writing. Side agreements have not been made.
- 3) **If the Contractor is a partnership or a consortium, this Pact must be signed by all the partners or by one or more partner holding power of attorney signed by all partners and consortium members. In case of a Company, the Pact must be signed by a representative duly authorized by board resolution.**
- 4) Should one or several provisions of this Pact turn out to be invalid; the remainder of this Pact remains valid. In this case, the parties will strive to come to an agreement to their original intentions.
- 5) It is agreed term and condition that any dispute or difference arising between the parties with regard to the terms of this Integrity Agreement/Pact, any action taken by the Owner/Principal in accordance with this **Integrity Agreement/ Pact or interpretation** there of shall not be subject to arbitration.

ARTICLE 8 LEGAL AND PRIOR RIGHTS

All rights and remedies of the parties hereto shall be in addition to all the other legal rights and remedies belonging to such parties under the Contract and/or law and the same shall be deemed to be cumulative and not alternative to such legal rights and remedies aforesaid. For the sake of brevity, both the Parties agree that this Integrity Pact will have precedence over the Tender / Contract documents with regard any of the provisions covered under this Integrity Pact.

IN WITNESS WHEREOF the parties have signed and executed this Integrity Pact at the place and date first above mentioned in the presence of following witnesses:

(For and on behalf of Principal/ Owner)

(For and on behalf of Bidder/ Contractor)

WITNESSES:

1. . (Signature, name and address)

2. . (Signature, name and address)

Place:-

Dated:

ALL INDIA INSTITUTE OF MEDICAL SCIENCE RAIPUR
Percentage Rate Tender/ Item Rate Tender & Contract for Works

Tender for the work of: “**Augmentation of Existing Electrical Distribution system for Phase- 1 (In Substation- 2, 3, 4 and Hospital Block) at AIIMS Raipur.**”

e- T E N D E R

I/We have read and examined the notice inviting tender, schedule, A,B,C,D,E & F, specifications applicable, Drawings & Designs, General Rules and Directions, Conditions of Contract, clauses of contract, Special conditions, Schedule of Rate & other documents and Rules referred to in the conditions of contract and all other contents in the tender document for the work.

I/We hereby tender for the execution of the work specified for the AIIMS Raipur within the time specified in Schedule 'F', viz., schedule of quantities and in accordance in all respects with the specifications, designs, drawings and instructions in writing referred to in Rule-1 of General Rules and Directions and in Clause 11 of the Conditions of contract and with such materials as are provided for, by, and in respects in accordance with, such conditions so far as applicable.

I/We agree to keep the tender open for **One Hundred Eighty (180) days** from the due date of opening of financial bid and not to make any modification in its terms and conditions.

~~A sum of **EMD** is hereby forwarded in Receipt Treasury Challan/ Deposit at Call Receipt of a Scheduled Bank/ Fixed Deposit Receipts of a Scheduled Bank/ Demand Draft of a Scheduled Bank/ Bank Guarantee issued by a Scheduled Bank as earnest money. A copy of the earnest money in Receipt Treasury Challan/ Deposit at Call Receipt of a Scheduled Bank/ Fixed Deposit Receipts of a Scheduled Bank/ Demand Draft of a Scheduled Bank/ Bank Guarantee issued by a Scheduled Bank is submitted with tender.~~ If I/We, fail to furnish the prescribed performance guarantee within prescribed tender, I/we agree that the said President of India or his successors, in office shall without prejudice to any other right or remedy, be at liberty to forfeit the said ~~earnest money~~ absolutely. Further, if I/We fail to commence work as specified, I/We agree that President of India or his successors in office shall without prejudice to any other right or remedy available in law, be at liberty to forfeit the said performance guarantee absolutely. The said Performance Guarantee shall be guarantee to execute all the works referred to in the tender documents upon the terms and conditions contained or referred to those in excess of that limit at the rates to be determined in accordance with the provision contained in Clause 12.2 and 12.3 of the General Conditions of Contracts (CPWD). Further, I/we agree that in case of forfeiture of ~~earnest money~~ or performance guarantee as aforesaid, I/We shall be debarred for participation in the re-tendering process of the work.

I/We undertake and confirm that eligible similar work(s) has / have not been got executed through another contractor on back to back basis. Further that, if such a violation comes to the notice of Department, then I/We shall be debarred for tendering in AIIMS Raipur in future forever. Also, if such a violation comes to the notice of Department before date of start of work, The Engineer – in – Charge shall be free to forfeit the entire amount of ~~Earnest Money Deposited~~ / Performance Guarantee.

I/We hereby declare that I/we shall treat the tender documents drawings and other records connected with the work as secret/confidential documents and shall not communicate information/derived therefrom to any person other than a person to whom I/We am/are authorized to communicate the same or use the information in any manner prejudicial to the safety of the State.

Dated #.....

Signature of Contractor#
Postal Address#

Witness : #

e-Mail id#

Address: #

Occupation: #
applicable

To be filled in by the contractor/witness as applicable

ACCEPTANCE

The above tender (as modified vide letters mentioned hereunder) is accepted by me for and on behalf of the AIIMS Raipur for a sum of ₹. _____*

(Rupees _____*)

The letters referred to below shall form part of this contract Agreement:-

a) _____*

b) _____

c) _____

For & on behalf of the AIIMS Raipur.

Signature.....

Dated

Designation.....

GENERAL PARTICULAR & ADDITIONAL CONDITIONS OF CONTRACT

1. Name of Work: “**Augmentation of Existing Electrical Distribution system for Phase- 1 (In Substation- 2, 3, 4 and Hospital Block) at AIIMS Raipur.**”
2. For all items of **Civil/Electrical/AC&R/Horticulture**;- CPWD specifications with up to date correction slips up to receipt of tender shall be followed. For the items which are not covered under CPWD Specifications; B.I.S. specifications shall apply. In this regard the decision of Engineer-in- charge shall be final.
3. Wherever any reference is made of any Indian Standard, it shall be taken as reference to the latest edition with all amendments/ revision issued thereto up to the date of receipt of tenders.
4. Unless otherwise specified, the agreement rates for all items of work of the schedule of quantities are for all heights, depths, leads and lifts involved in the execution of work.
5. Other agencies working at site will also simultaneously execute the work entrusted to them and the contractor shall offer necessary co-operation wherever required to other agencies.
6. On account of security consideration, there could be some restrictions on the working hours, movement of vehicles for transportation of materials. The contractor shall be bound to follow all such restrictions and adjust the program for execution accordingly, for which nothing extra shall be paid.
7. The work shall be carried out in a manner complying in all respects with the requirements of relevant bye laws of the local bodies, Labour Laws, minimum wages act, workmen compensation act and other statutory laws enacted by Central Govt. as well as State Govt.
8. All melba/rubbish/silt/waste, garbage etc. generated due to any operation from buildings/houses/hostels and other open spaces whatsoever shall be disposed off on daily basis by the contractor to the specified common disposal point. After the collection of full truck load of the said Melba (approx. 4.5 cubic meters), the same shall be disposed off by the contractor to the authorized municipal dumping ground and nothing extra shall be paid on this account. In case of non- removal/disposal in the specified period, the same would be disposed at risk & cost of contractor.
9. No residential accommodation shall be provided to any of the staff engaged by the contractor. The contractor shall not be allowed to erect any temporary set up for staff in the campus.
10. No claims of the labours shall be entertained by the Department including that of providing employment, regularization of services etc.
11. All required register will be issued by Engineer-in-Charge/Executive Engineer duly marked in chronological order but the contractor will have to arrange all such registers/stationery etc. Nothing extra shall be paid on this account.
12. The contractor shall have registration with Employee’s Provident Fund commissioner and Employee’s state Insurance Corporation for safe guarding interest of his workmen. He shall obtain all other necessary approvals from statutory bodies as per law in vogue.
13. All T&P, scaffoldings, ladders/Hydra etc, instruments/meters for maintenance, consumable and Contingent Articles required for execution of the work shall be arranged by the contractor.
14. The contractor shall make all safety arrangement required for the labour engaged by him at his own cost. All consequences due to negligence or due to lapse of security/safety or otherwise shall remain with the contractor. The department shall not be responsible for any

- mishap, injury, accident or death of the contractor's staff. No claim in this regard shall be entertained / accepted by the department. Also Contractor is responsible to the damage caused to any man/material other than his team during execution and AIIMS will not be responsible for that.
15. Contractor shall be fully responsible for any damages caused to govt. property or allotter's property by his or his labor in carrying out the work and shall be rectified by the contractor at his own cost.
 16. GST and other Taxes as applicable shall be recovered/ paid from the contractor's bill as per Govt. of India/AIIMS Rules. GST amount will be reimbursed only after submission of GST deposition proof.
 17. Chases, holes & drilling works etc. shall be done using power operated tools in the cost of Contract. No extra will be paid for the same.
 18. The agency shall restore back the premises and other articles provided by the department to the department at the time of closure of the contract.
 19. In the case of discrepancy between the schedule of quantities, the Specifications and/or the Drawings, the following order of preference shall be observed :-
 - (a) Description of schedule of quantities.
 - (b) Additional specifications and special conditions, if any.
 - (c) Contract clauses of General conditions of contract for Central P.W.D. works. (iv) CPWD specifications.
 - (d) Architectural drawings.
 - (e) Indian standards specifications/ BIS. (vii) Sound engineering practice. Any reference made to any Indian standards specifications in these documents, shall imply to the latest version of that standard, including such revisions/amendments as issued by the Bureau of Indian Standards up to last date of receipt of tenders. The contractor shall keep at his own cost all such publications of relevant Indian Standards applicable to the work at site.
 20. The contractor and /or his authorized agent should see the site order book every day and get the compliance of instruction given by the JE/AE/Engineer-in-charge (E-I/C) as per time schedule.
 21. The contractor will not pitch up tents for laborers, materials and his stores etc.
 22. No permanently / temporary huts / structures shall be constructed by the contractor at the site of work or at any government land / premises. Such structures, if any, found at the site or at AIIMS, Raipur land shall be demolished and removed at the cost of the agency without any notice.
 23. Any damage to the building structure, fittings or any other articles etc. done by the contractor or his workman during the execution of the work shall be made good by the contractor at his own cost.
 24. The contractor shall clear the site properly after the completion of the work.
 25. The Agency shall be solely responsible for compliance to the provisions of various Labor and industrial laws, such as, wages, allowances, compensations, EPF, Bonus, Gratuity, ESI etc. relating to personnel deployed by it at AIIMS, Raipur site or for any accident caused to them and the institute shall not be liable to bear any expense in this regard. The Agency shall make payment of wages to workers engaged by it by the stipulated date irrespective of any delay in settlement of its bill by AIIMS, Raipur for whatever reason. The

Agency shall also be responsible For the insurance of its personnel. The Agency shall specifically ensure compliance of various Laws / Acts, including but not limited to with their re-enactments / amendments / modifications etc.

- (a) The Payment of Wages Act 1936.
- (b) The Employees Provident Fund & MP Act, 1952.
- (c) The Contract Labor (Regulation) Act, 1970.
- (d) The Payment of Bonus Act, 1965.
- (e) The Payment of Gratuity Act, 1972.
- (f) The Employees State Insurance Act, 1948.
- (g) The Employment of Children Act, 1938.
- (h) The Motor Vehicle Act, 1988.
- (i) Minimum Wages Act, 1948.

26. **Breach of Terms and Conditions:** Noncompliance of any terms and conditions enumerated in the contract shall be treated as breach of contract. Or In Case of breach of any terms and conditions as mentioned above, the Competent Authority, will have the right to reject the bid at any stage without assigning any reason thereof and nothing will be payable by AIIMS, Raipur in that event the ~~EMD~~ and /or Performance Guarantee and/or security deposit shall also stands forfeited.
27. **Arbitration:** The Arbitration shall be held in accordance with the provision of the Arbitration and conciliations Act, 1996 and the venue of arbitration shall be at Raipur. The decision of the Arbitrator shall be final and binding on the both parties.
28. **Dispute Settlement:** It is mutually agreed that all differences and disputes arising out of or in connection with this agreements shall be settled by mutual discussions and negotiations if such disputes and differences cannot be settled and resolved by discussions and negotiations then the same shall be referred to the sole Arbitrator appointed by the Director, AIIMS, RAIPUR whose decision shall be final and binding on both the parties. The contract shall be governed by laws and procedures established by Govt. of India, within the framework of applicable legislation and enactment made from time to time concerning such commercial dealings/ processing.
29. Guidelines issued by Hon'ble National Green Tribunal in O.A. No. 21 of 2015 and O.A. No. 95 of 2014 in the matter of Vardhaman Kaushik Vs. Union of India & other and Sanjay Kulshreshtha Vs Union of India & ors: Air Pollution of Dust from Construction and Demolition activity reg. issued vide letter No. DPCC/EIA/Ref-001 to 172/NGT-21/2015/225-408 dt. 17/04/2015 shall be complied by the Bidders.
30. The sample of all the items shall have to be got approved by the Contractor from the Engineer-in-Charge/Executive Engineer or his Representative before the supply commences, the approval of sample shall be only in respect of workmanship and finish, and shall be without prejudice to the right of Engineer-in-Charge to get random samples tested out of the actual lot received as per additional conditions. This decision is the Prerogative of Engineer-in-Charge.
31. The contractor shall furnish the manufacturer's certificate that the materials supplied satisfy the requirements of the relevant specifications.
32. The Engineer-in-Charge shall be at liberty to test respective sample (s) of each item of schedule of quantity in any approved laboratory as decided by him. The sample for testing shall be provided by the contractor. If the test proves satisfactory and the material is accepted, the testing charge in respect of satisfactory test shall be borne by the department.

All other expenditure required to be incurred for making available the sample, conveyance

and packing etc, shall be borne by the contractor himself. In case any sample of particular lot fails in testing the contractor shall be bound to replace the entire lot with fresh material of prescribed specifications and the rejected lot shall only be returned to the contractor after fresh lot is supplied. Testing charges in respect of failed sample will be borne by the contractor himself.

33. Rejected materials shall have to be removed by the contractor at his own cost at once.
34. In case of any dispute regarding rejection of quantity of materials the decision of Engineer-in- Charge shall be final and binding upon the contractor.
35. Conditional tenders are liable to be summarily rejected.
36. Composite register issued by Engineer-In-charge must be maintained by representative of E-I-C and contractor both. The contractor or his representative is bound to sign the Composite register as and when required by the Engineer-in-Charge and to comply with the remarks therein.



SCOPE OF WORK AND TECHNICAL SPECIFICATIONS FOR ELECTRICAL WORKS

A) Scope of work:-

The scope of supply and work for electrical jobs consists of the following:

- 1) Supply, installation and testing and commissioning of new LT switch gear panels (PCC, PDB, Floor Panels & Change over panels) as per schematic drawings given in tender document.
- 2) Modification and extension of existing substation main LT panel (PCC).
- 3) Bus bar modification and retrofitting circuit breakers, MCCB, in existing panels.
- 4) Supply, laying and Termination of LT power and control cables with cable glands, lugs etc.
- 5) Supply and installation of cable supports and GI cable trays.
- 6) Supply, fabrication and installation of MS structure for support of cables and panels.
- 7) Supply and fixing of GI flats for earthing and connecting to existing network.
- 8) Testing and termination of LT power and control cables.
- 9) Foundation and other minor civil work required for electrical installation work.
- 10) Description of work under Annual Maintenance Contract (AMC)
 1. Regular inspection of equipment offered, minimum at every 3 months or as instructed by Engineer-in-charge. This shall cover checking of terminals, temperature rise, any arcing or burnouts, cleaning etc.
 2. Attend breakdown and troubleshooting as & when occurred.
 3. Take Preventive/corrective/predictive maintenance timely and report to Engineer-in-charge.
 4. Provide professional, skilled & semi-skilled manpower for maintenance of all the newly installed equipment under this tender/agreement.
 5. Relays and Breakers shall be checked for functioning.
 6. All the equipment shall be provided preventive maintenance as per manufacturer's recommendations or as required by engineer in charge on monthly/quarterly/six monthly/ yearly basis for which suitable specialized personnel/ engineer will be provided.
 7. Any component failure due to bad quality and poor maintenance, shall be replaced free of cost. This will be in addition to replacement of defective components within guarantee period.
 8. Agency will support for termination/ connection of cables in feeder installed by him during period of maintenance if required by the AIIMS.
 9. Maintain Log Book for Maintenance of all Equipment including checking of contact resistance of Joints, Terminals, Breaker poles and their cleaning in standard format as issued by Engineer-in-charge.

10. Agency has to provide list of all major and minor spare items used in installation and which shall be required for maintenance from 2nd year of AMC period.

B) General Technical requirements :-

- 1) Supply of all electrical items shall be from list of approved vendors.
- 2) Routine Tests to be conducted on all panels and test certificates to be submitted.
- 3) All main panels shall be of type tested.
- 4) All panels shall be from reputed manufacturers having advanced process of manufacturing.
- 5) Thermal (O/L) setting and Magnetic settings of all MCCBs shall be adjustable.
- 6) The incoming terminals of panel type 'D' shall be suitable for terminating extra cable for looping.
- 7) All items shall confirm to technical specifications enclosed.
- 8) Site measurements shall be taken for installation of panels at proposed site.
- 9) Existing Bus Bar dimensions shall be taken for the panel extension and retrofitting of breakers on existing panels. Shutdown will be arranged by purchaser as per requirements and convenience of operation.
- 10) Offers shall be submitted with item wise price as per tender schedule.
- 11) Detailed installation and layout drawings will be issued to the contractor, by Engineer-in-charge after issue of work order.
- 12) Minor modification in existing civil foundation work, required for installation of equipments and cable laying, shall be carried out by the contractor without any extra cost.
- 13) GA drawings, technical data sheets and instruction manuals shall be supplied for all panels and bought out items.
- 14) All safety precautions shall be followed during installation work of all items.
- 15) All panels and feeders shall be marked by with designations.
- 16) Cable tags shall be provided at both ends with durable type cable tags.
- 17) Civil foundations required for installation of panels, where foundations will be raised by 300mm, will be done by the contractor. Necessary civil drawing to be submitted by party for approval. The foundation will be complete with inserts for mounting panels, SS hand railing, base channels etc.
- 18) The LT panels shall be manufactured as per IEC: 61439 and the panel builder shall produce type test certificates of panels and valid design from OEM.**
- 19) The work shall be carried out strictly in accordance with CPWD specifications for Electrical Works 2013 (internal), 1995 (External) and 2013 (Substation), as amended up to date and in accordance with Indian Electricity Rules, 1956, Indian Electricity Act, 1910 as amended upto date and as per instructions of the Engineer-in-Charge including as below and nothing will be paid extra.

- 20) All materials to be used on this work shall be ISI marked & shall be got approved in written from the Technical sanctioning authority/Engineer-in-Charge before installation at site unless otherwise not covered under ISI.
- 21) PVC insulated Cu conductor wire used shall be multi-standard FRLS grade for which nothing extra shall be paid.
- 22) The work shall be carried out according to approved drawings/details which shall be subsequently issued to the successful tenderer for execution of work and as per instructions of Engineer-in-Charge who will have the right to change the layout as per requirement at site and the contractor shall not have any claim due to change in layout. The work shall be executed by skilled person Licensed by the approved authorities.
- 23) The size of conduit and wiring shall be got approved from the Engineer-in-Charge before taking up the execution.
- 24) The contractor shall make his own arrangement at his own cost for electrical / general tools and plants required for the work. Main Board and Main Distribution Board: The work shall be carried out according to the drawings / details are as approved by the Engineer- in-Charge. The contractor shall have to get the samples approved before the whole lot is brought to site and it shall include all inter connections etc. All termination of electrical cables in panel / feeder pillars DB's, cable-looping box etc. shall have to be done with proper thimbles / Cu lugs using crimping process. Copper thimbles / reducer shall be used for copper cable and Aluminum cable nothing extra will be paid for the same.
- 25) All materials shall be supplied and used in items of works by the contractor should be of standard and approved quality. They should be got approved from the Engineer-in-Charge or his authorized representative before installation otherwise no payment will be made for an unapproved or rejected material used on the works and the same shall be removed at his cost from site or work.
- 26) The contractor shall have to prove bonafide of the make of materials by producing necessary documentary evidence. They are advised to obtain prior approval of Engineer-in-Charge for proposed make of material, before bringing material to site work.
- 27) Location of light fixtures, cable routes, power & light point etc. should be prepared & got approved from the Engineer-in-Charge before execution.
- 28) All interconnection in the panel, DB, cable-looping boxes shall be carried out with suitable cable commensurate with the current carrying capacity of incoming and outgoing cables complete with thimbles etc. as required for which nothing extra shall be paid.
- 29) All panels, DB's, cable-looping boxes will be numbered and marked with paint / name plate, ferruling of circuit/submain etc and nothing extra will be payable on this amount.
- 30) All MCB, MCCB, MCB, DB's, RCBO's, RCCB with DB's shall be of same make / manufacturer.
- 31) Modular Switch / Socket's / Plates / Computer outlet / Telephone outlet and all accessories shall be of the single make only be provided. The contractor shall have to make the edges around the boxes wherever required shall have to be

made by the contractor for which nothing extra shall be paid. The galvanized metal box shall be of the standard thickness as the GI boxes besides other requirement.

- 32) All the material should be ISI Marked unless otherwise clarification is not available and approved by the E-I-C.
- 33) The entire installation shall be at the risk and responsibility of the contractor until these are tested and handed over to the department.
- 34) Notwithstanding the schedule of quantities, all items of interrelated works considered necessary to make the installation complete and operative are deemed to be included shall be provided by the contractor at no extra cost.
- 35) The connection, inter connection, earthing and inter earthing shall be done by the contractor wherever required and noting extra shall be paid on this account All repairs & patch work shall be neatly carried out to match with the original finish & all damages caused to the building installation during the execution of work shall have to be made good by the contractor immediately at his own cost to the entire satisfaction of Engineer-in-charge. In case contractor fails to comply with the instructions of the Engineer-in-charge, Engineer-in-charge shall be at liberty to get the work done by any other agency and recover such amount as paid to the other agency from the bill(s) of the contractor. Contractor shall have no claim, whatsoever, on the extent of such amount.
- 36) The contractor shall have to provide the fish wire after removing the choking of the conduits. Even if subsequently the conduits are found chocked, the choking will be get removed and / or the new conduits shall be provided at the risk and cost of the contractor.
- 37) Wherever ceiling roses are not required to be provided in the light/fan/exhaust fan points, due to site conditions, the contractor shall use suitable three pin connectors for which nothing extra shall be paid. Wiring shall be carried out with FRLS wires.
- 38) Contractor shall provide polythene/PVC plastic cover for all MDB's/SDB's/DB's, panels, feeder pillars etc to protect them from rust/damages, during execution of work till the work is actually completed and handed over to the department.
- 39) Makes of all items that are not covered in the schedule of work/additional specifications shall be got approved from the Engineer-in-charge and shall conform to relevant Indian Standard as applicable.
- 40) The contractor shall ensure that the staff employed by him for execution of the electrical work, possess the valid electrical license issued by competent authority. Consequences arising due to the default of the contractor in not complying with the above condition shall be the responsibility of the contractor.
- 41) Copper lugs shall be provided for terminating copper/aluminium/GI earth wire to all switchboards for which nothing extra shall be paid. All multi-stranded/stranded wires shall be terminated through copper lugs.
- 42) All the hidden work and earthing shall be done in the presence of the Engineer-in-charge or his authorized representative.
- 43) The schematic diagram/dimensional drawings of the various electrical cubical panels shall be got approved from the Engineer-in-charge before fabrication and

shall comply with CPWD specifications and Indian Electricity Rules. The panels shall conform to IS: 8623/1993. All panels shall be powder coated inside out, in shade approved by the Engineer-in-charge.

- 44) All floor-mounted panels shall be mounted on M.S. channel of suitable size on all the sides. It shall have a continuous earth bus of the same size and material as the main phase running continuously along the length of the panel extending on either side for earth connection.
- 45) The doors of all cubicle panels shall be hinged type including those of bus bar chambers and cable alleys. The locking shall be with chrome plated metal key locks. All doors shall be earthed with copper conductor wire as approved by the Engineer-in-charge.
- 46) The work shall be carried out according to drawing approved by the Engineer-in-charge. The layout once approved can only be changed by the Engineer-in-charge as per requirement at site. It shall be the responsibility of the contractor to plan the layout and get the approval from the Engineer-in-charge before laying the conduits etc.
- 47) The MCB should be of the same make as that of MCB DB's and having a minimum breaking capacity of 10 KA, C-curve. Contractor shall obtain approval of the Engineer-in-charge before procurement of MCB DB's.
- 48) All model of modular accessories required for the work shall be got approved from the Engineer-in-charge from among the approved makes. The base plate shall be preferably in sheet steel or otherwise in unbreakable polycarbonate. The cover plates shall be screw less type in shade approved by the Engineer-in-charge.
- 49) MCCBs shall be used with terminal spreaders and all terminals shall be shrouded to avoid direct contact.
- 50) All measuring and indicating instruments shall be protected through MCB's and isolating switches.
- 51) General arrangement drawing of the switchboard shall be prepared and got approved from the Engineer-in-Charge before commencement of manufacturing/installation.
- 52) For the items like LT panels, feeder pillars and accessories, etc, the firm shall arrange for inspection in the factory and provide for all facilities for testing. The cost of the visit of Engineer-in-Charge or his representative shall be borne by contractor. However, firm will be responsible for arranging the inspections as required.
- 53) Conduit layout as per switching arrangement shall be prepared by contractor and got approved from the Engineer-in-Charge before slab casting.
- 54) Conduit and termination to SDB and main board adapter box i/c connection wires to MCB,s inter connection between SDB and main board etc shall be included in the tendered rates and nothing extra shall be paid for the same.
- 55) The contractor shall provide junction boxes / looping boxes of required sizes and such boxes shall be measured as part of conduit / batten wiring without any extra payment.

- 56) M.S. dash fastener shall be used for installation of fittings and fixtures in ceiling and for providing suspenders for the angle support, conduiting, cable tray etc. for which nothing extra shall be paid
- 57) All CI/metal boxes & junction boxes should be cleaned properly and painted from inside before wiring & fixing the accessories.
- 58) Cables:-
 - (a) Cables shall be bought from manufacturer only as per approved NIT.
 - (b) The length of the cables required shall be measured w.r.t. site condition and these shall be delivered in section of approved length only, to avoid jointing as far as possible.
 - (c) Cable delivery shall be scheduled in consultation with department only.
- 59) Conduit layout drawing shall be got approval by Engineer -in-Charge before laying of conduit.
- 60) Conformity to specifications:-
 - (a) PVC insulated copper wire used shall be ISI marked and wire of the size 4.00 Sq. mm and above shall be of stranded conductors and all standard wires are required to be crimped for connections / terminations.
 - (b) All accessories like switches, sockets, C/roses, holders shall be ISI marked.
 - (c) Phenolic laminated sheet be of only ISI Marked. Covers for adopter box and function box shall also be of white phenolic laminated sheet.
- 61) Earthing connections:-
 - (a) All fans & fittings are to be properly earthed for which no extra will be paid
 - (b) Proper sleeving is to be provided to bare earth conductor in the switch boxes and also to bare Conductors used for inter switch looping inside the switch boxes for which no extra will be paid.
 - (c) Termination of wiring inside DB's & main boards should be by crimped connections
 - (d) Clamp type termination of earth strip (wherever provided) to pipe electrode will be made
- 62) Date of acceptance of the installation
 - (a) After the Engineer – in – Charge is satisfied that the installation complies with requirements of specifications in all respect
 - (b) The entire installation shall be at the risk and responsibility of the contractor until these are tested and handed over to the department. However, if there is any delay from the department side, the installation may be taken over in parts but the decision on the same shall be binding on the contractor
- 63) To carryout specialized or non-specialized work of electrical nature, technical labour to be minimum ITI qualified and should have experience of Electrical safety & wiring rules & to be authorized by contractor or sub-contractor.

- 64) Technical Specifications Compliance Report (Annexure-“I”, “II”, “III” etc., if any) of LED fitting should be filled & get approved with supporting test report in written from the Engineer-in-Charge before supply/use at site.

C) Technical specifications:

GENERAL TECHNICAL SPECIFICATION FOR POWER DISTRIBUTION BOARDS (PCC, PDB, FLOOR DB & CHANGE OVER PANELS)

1 Standards and Regulations

The equipment shall be designed, manufactured, assembled, tested in accordance with latest revisions of relevant Indian standard specifications and IE rules, IS: 13947-1993, IS:732-1989

2 Tests

a) Routine test:

All routine tests shall be conducted and test certificates shall be submitted to the purchaser as per relevant standards.

b) Type test;

The type of panels supplied shall be type tested, the tests being done earlier on similar panels and certificates obtained.

3 Drawings and documents to be submitted after placement of order (5sets)

a) GA drawing indicating inscriptions, cable entry position, foundation outline, load data, bolt hole etc.

b) Schematic diagram with make and detailed specifications of components to be used along with technical catalogues.

c) Test certificates.

d) Operation and maintenance instructions.

4 TECHNICAL SPECIFICATIONS

4.01 Power supply system

Supply Voltage : 3 phase, 4 wire 415V, 50 HZ AC

Voltage variation : +/- 10%

Frequency variation : (+) 3%, (-) 6%

Symmetrical fault level : 50KA

System earthing ; solidly earthed neutral

4.02 Ambient conditions

Ambient temperature : 50 Cmax.

Relative humidity : 95%

Atmosphere : Dusty

4.03 Constructional Features

1) All the panels shall be floor mounting, compartmentalized modular type, free standing having separate doors for each module.

2) The workmanship and material shall be suitable for heavy duty. The power

distribution boards shall be sheet steel (thickness not less than 2 mm) enclosed, conforming to IP-54 as per IS:2147 floor mounting type, Direct access to all the equipment from the front and ample cabling space shall be provided.

- 3) All the boards shall be with individual sheet steel hinged door with sponge rubber gaskets to make the unit dust tight. The hinges and fasteners shall be concealed. The enclosures shall be designed in such a way that all the breakers can be operated from outside with rotary handle. Door interlock shall also be provided with breaker operation so that door can be opened in OFF position only.
- 4) All back doors bolted type & cable alley doors shall be hinged type.
- 5) Cable entry for cables shall be at the bottom / Top of the cabinets as indicated in the single line diagram. Accordingly Detachable cable entry gland plates shall be provided.
- 6) Power terminals shall be provided for each incomer and outgoing for termination of cables of required size. Power terminals shall be at least 200mm above or below the gland plate.
- 7) Any operating mechanism shall be mounted at min. 300mm ht. from floor level.
- 8) Base channel shall be provided for each panel i.e. 100mm for PCC extension panels and 75mm for all other panels.

4.04 Inscriptions /labelling.

Respective board numbers shall be painted in front of the boards as per single linediagram enclosed. Engraved inscription plates of non-hygroscopic and non-deteriorating material, with mechanism number and description single line shall be provided on each compartment door.

4.05 Bus bars &connections

- 1) The panel shall have 3 Phase & Neutral bus bars. The horizontal and vertical bus bars and connections shall be of high conductivity electrical grade Aluminium type E91E as per IS :5082.
- 2) The connections shall be adequately held together by clamps or through bolts to withstand the fault. The bus bar shall be covered with heat shrinkable PVC sleeve and phase identified by the colors red, yellow and blue.
- 3) All connections shall be air insulated and shall have minimum air clearance to earth and between phase not less than 25mm. The ratings of the bus bars are indicated in the single line diagrams.
- 4) Earth Bus shall be provided at the bottom of the panel.
- 5) All bus bars shall have short time rating of 50 KA for 1 sec.

4.06 Moulded case circuit breakers (MCCB)

All incomer MCCBs shall be 4 pole 500V,AC ratings as indicated.

Breaking capacity ; 50KA,

Protections ; MCCB 250A and above: over Load, S/C & E/F protection (microprocessor type release with communication port)
 Aux. Switch : 1 NO +1NC
 Trip micro switch : provided for indication.

All out going. MCCBs / 63A / 125A / 200A

Protections : Over Load and S/C protection (Thermo magnetic type release)
 Aux. Switch : 1 NO +1NC
 Trip micro switch : provided for indication.

4.07 Earthing:

A continuous earth bus shall be provided for full length of PDBs at the bottom with earth terminal at both ends.

4.08 Painting

All metallic parts of the PDB shall be thoroughly degreased, de-rusted, through seven tank process before painting/finishing with epoxy powder paint, Color shall be light gray as per shade no.631 of IS: 5.

Each PDB shall have one incomer and number of outgoing feeders as indicated in single line diagrams

4.09 Indications and metering:

Lamp indications shall be provided for all incomers and outgoings by LED lamps, Volt meters and Ammeters for incomers only.

Incomers:

1. Red, Yellow, blue for incoming line indication lamp.
2. ON/OFF/Trip for breaker status indication lamp.
3. Volt meter with selector switch, digital type, control fuse.
4. Ammeter with selector switch, digital type and CT for 3phases.

Outgoings: ON / Trip lamp for breaker status indication

D) ELECTRICAL PANEL DETAILS:

TYPE 'A' PANEL

Head	Description	Remark
Type	Floor mounted panel and - extension of panel & bus in line with existing PCC panel, modular, compartmentalized, Sheet steel enclosed, IP:54 as per T.S.	
Incomer	Bus adopter for extension of existing PCC bus at one end, including modifications on existing Bus Bar, new flats, drilling and Bolting, insulator supports etc.	
Bus bar	3 Phase & N, 500V, AC, 1000A, Short time rating 50 KA for 1 sec. high conductivity , Electrical grade Aluminium.	
Out Goings	MCCB, 4 pole, 500V, AC, Electrically operated, draw out type with Microprocessor type release for O/L, S/C & E/F protection, Auxiliary and trip micro switch.	
	630A	1 Nos.
	400A	2 Nos.
	315A	3 Nos.
	250A	2 Nos.
Indications	Outgoing breaker ON & Trip indication LED R, Y, B. Line indication.	30 Nos.
Metering	Digital ammeter with selector switch for all out goings Digital Volt meter with selector switch for Incomer Control MCB. DP 6A	6 Nos.
Control	Push Button ON / OFF on panel door for each breaker.	2 Nos.
Ref. drg. no	AIIMS/RSVP/01EE/SLD-A/EL/0151	

TYPE 'B' PANEL

Head	Description	Remark
Type	Floor mounting type panel, modular , compartmentalized, Sheet steel enclosed, IP: 54 as per T.S.	
Incomer	MCCB, 4 pole, 500V, AC, Electrically operated, draw out type with microprocessor based release for O/L, S/C and E/F protection, communication facility. auxiliary and trip micro switch rating 630A	1 No.
Bus bar	3 Phase &N, 500V, AC, 800A, Short time rating 50 KA for 1 sec., high conductivity, Electrical grade Aluminium.	
Out Goings	MCCB, 4 pole, 500V, AC, draw out type with Microprocessor type release for O/L, S/C & E/F protection,. auxiliary and trip micro switch	
	400A Electrically operated,	1 No.
	315A Electrically operated,	1 No.
	200A Manually operated,	4 Nos.
	125A Manually operated,	3 Nos.

Indications	Incomer breaker ON/OFF & Trip indication LED RED, Yellow, Blue line indication Outgoing breaker ON & Trip indication LED	34 Nos.
Metering	Digital ammeter with CT, selector switch for Incomer & Two outgoing.	3 sets.
	Digital Volt meter with selector switch for Incomer	1 Set
	Control MCB. DP 6A	2 Nos.
Control	Push Button ON / OFF on panel door for each breaker.	6 Nos.
Ref. drg. no	AIIMS/RSVP/01EE/SLD-B/EL/0152	

TYPE 'C' PANEL

Head	Description	Remark
Type	Floor mounting type panel, modular, compartmentalized, Sheet steel enclosed, IP: 54 As per T.S.	
Incomer	MCCB, 4 pole, 500V, AC, Electrically operated, fixed type with microprocessor based release for O/L, S/C and E/F protection, communication facility. Auxiliary and trip micro switch.400A	1 No.
Bus bar	3 Phase & N,500V AC, 500A,Short time rating 50KA for 1sec. high conductivity , Electrical grade Aluminium.	
Out Goings	MCCB, 4 pole, 500V, AC, Electrically operated, fixed type with Electromagnetic type release for O/L, S/C protection, auxiliary and trip micro switch	
	250A, Electrically operated, fixed type	1 no.
	200A Manually operated, fixed type	3 Nos.
	125A Manually operated, fixed type	2 Nos.
Indications	Incomer breaker ON OFF & Trip indication LED RED, Yellow, Blue line indication. Outgoing breaker ON & Trip indication LED	21 Nos.
Metering	Digital ammeter with selector switches for Incomer and250 A outgoing.	2 sets
	Digital Volt meter with selector switch for Incomer	
	Control MCB. DP 6A	2 nos
	Push Button ON / OFF on panel door for each breaker.	4 Nos.
	Inter locking relays, timers, selector switch MCB for interlocking between I/C and 250A out going.	1 set
Ref. drg. no	AIIMS/RSVP/01EE/SLD-B/EL/0153	

TYPE 'D' CHANGE OVER PANEL

Head	Description	Remark
Type	Floor mounting /Wall mounting type panel, modular, compartmentalized. Sheet steel enclosed, IP: 54 AS PER T,S,	
Incomer	MCCB, 4 pole, 500V, AC, Electrically operated, fixed type with microprocessor based release for O/L, S/C and E/F protection, communication facility. Auxiliary and trip micro switch.200A. 50 KA for 1 sec.	2 sets
Bus bar	3Phase & N, 500V AC, 200A, Short time rating 50KA for1 sec. high conductivity , Electrical grade Aluminium.	
Indications	Incomer breaker ON OFF & Trip indication LED RED , Yellow, Blue line indication	12 Nos.
Metering	Digital ammeter with selector switches for both Incomer	2 sets.
	Digital Volt meter with selector switch	1 Set.
	Control MCB. DP 6A	2 nos
	Push Button ON / OFF on panel door for each breaker.	4 Nos.
	Auto changeover scheme with timer, aux. relays, control transformer, indication lamps, selector switches.	lot
Ref. drg. no	AIIMS/RSVP/01EE/SLD-B/EL/0154	

Annexure I**FORM OF EARNEST MONEY DEPOSIT****{Bank Guarantee Bond}**

~~WHEREAS, contractor..... (Name of contractor) (Hereinafter called "the contractor") has submitted his tender dated..... (date) for the construction of (name of work) (hereinafter called "the Tender")~~

~~KNOW ALL PEOPLE by these presents that we (name of bank) having our registered office at (hereinafter called "the Bank") are bound unto (Name and division of Executive Engineer) (hereinafter called "the Engineer in Charge") in the sum of Rs. (Rs. in words) for which payment well and truly to be made to the said Engineer in Charge the Bank binds itself, his successors and assigns by these presents.~~

~~SEALED with the Common Seal of the said Bank thisday of 20.... THE CONDITIONS of this obligation are:~~

~~(1) If after tender opening the Contractor withdraws, his tender during the period of validity of tender (including extended validity of tender) specified in the Form of Tender;~~

~~(2) If the contractor having been notified of the acceptance of his tender by the Engineer in Charge:~~

~~(a) fails or refuses to execute the Form of Agreement in accordance with the Instructions to contractor, if required; OR~~

~~(b) fails or refuses to furnish the Performance Guarantee, in accordance with the provisions of tender document and Instructions to contractor,~~

~~We undertake to pay to the Engineer in Charge either up to the above amount or part thereof upon receipt of his first written demand, without the Engineer in Charge having to substantiate his demand, provided that in his demand the Engineer in Charge will note that the amount claimed by his is due to him owing to the occurrence of one or any of the above conditions, specifying the occurred condition or conditions.~~

~~This Guarantee will remain in force up to and including the date* after the deadline for submission of tender as such deadline is stated in the Instructions to contractor or as it may be extended by the Engineer in Charge, notice of which extension(s) to the Bank is hereby waived. Any demand in respect of this Guarantee should reach the Bank not later than the above date.~~

~~DATESIGNATURE OF THE BANK~~

~~WITNESS~~

~~SEAL (SIGNATURE, NAME AND ADDRESS)~~

~~*Date to be worked out on the basis of validity period of 6 months from last date of receipt of tender.~~

FORM OF PERFORMANCE GUARANTEE BANK GUARANTEE

(On a stamp paper of appropriate value from any Nationalized Bank or Scheduled Bank)

To
Executive Engineer,
AIIMS RAIPUR,
TATIBANDH,
RAIPUR – 492099

Dear Sir,

In consideration of the AIIMS RAIPUR, having offered to except the terms and conditions of the proposed agreement between..... & M/S_____ (hereinafter referred to as “the said Contractor (s)”, which expression shall include his successor and assignees) for the work of _____ Contract No _____ in terms inter alia, of the _____ Letter No. _____ dated _____ and the General Conditions of Contract and upon the condition of the Contractor's furnishing Security for the performance of the Contractor's obligations and discharge of the Contractor's liability under and in connection with the said Contract upto a sum of Rs. _____ (Rupees _____ only) amounting to _____ percent of the total Contract value.

- 1 We, _____ (hereinafter called 'The Bank' which expression shall include its successors and assignees) hereby jointly and severally undertake to guarantee the payment to the Employer in rupees forthwith on demand in writing and without protest or demur or any and all moneys payable by the Contractor to the Employer in respect of or in connection with the said Contract inclusive of all the Employer's losses and damages and costs, (inclusive between attorney and client) charges and expenses and other moneys payable in respect of the above as specified in any notice of demand made by the Employer to the Bank with reference to this guarantee upto an aggregate _____ limit of _____ Rs. _____ (Rupees _____ only).
- 2 We _____ Bank Ltd. further agree that the Employer shall be sole judge of and as to whether the said Contractor has committed any breach or breaches of any of the terms and conditions of the said Contract and the extent of loss, damage, cost, charges and expenses caused to or suffered by or that may be caused to or suffered by the Employer on account thereof and the decision of the Employer that the said Contractor has committed such breach or breaches and as to the amount or amounts of loss, damage, costs, charges and expenses caused to or suffered by the Employer from time to time shall be final and binding on us.
- 3 The Employer shall be at liberty without reference to the Bank and without affecting the full liability of the Bank hereunder to take any other Security in respect of the Contractor's obligations and liabilities hereunder or to vary the Contract or the work to be done there under vis-a-vis the Contractor or to grant time or indulgence to the Contractor or to reduce or to increase or otherwise vary the prices of the total Contract value or to release or to forbear from enforcement of all or any of the Security and/or any other Security(ies) now or hereafter held by The Employer and no such dealing(s) reduction(s) increase(s) or other indulgence(s) or arrangements with the Contractor or release or forbearance whatsoever shall absolve the bank of the full liability to the Employer hereunder or prejudice the rights of the Employer against the bank.

- 4 This guarantee shall not be determined or affected by the liquidation or winding up, dissolution, or change of constitution or insolvency of the Contractor but shall in all respects and for all purposes be binding and operative until payment of all monies payable to the Employer in terms thereof.
- 5 The bank hereby waives all rights at any time inconsistent with the terms of this guarantee and the obligations of the Bank in terms hereof shall not be anywise affected or suspended by reason of any dispute or disputes having been raised by the Contractor stopping or preventing or purporting to stop or prevent any payment by the Bank to the Employer in terms hereof.
- 6 The amount stated in any notice of demand addressed by the Employer to the Bank as liable to be paid to the Employer by the Contractor or as suffered or incurred by the Employer on account of any losses or damages or costs, charges and/or expenses shall be conclusive evidence of the amount so liable to be paid to the Employer or suffered or incurred by the Employer as the case may be and shall be payable by the Bank to The Employer in terms hereof.
- 7 This guarantee shall be a continuing guarantee and shall remain valid and irrevocable for all claims of the Employer and liabilities of the Contractor arising upto and until midnight of _____.
- 8 This guarantee is valid till _____ (date to be mentioned) (Sixty days beyond the stipulated date of completion or the extended period, thereof)
- 9 This guarantee shall be in addition to any other guarantee or Security whatsoever that the Employer may now or at any time anywise may have in relation to the Contractor's obligations/or liabilities under and/or in connection with the said Contract, and the Employer shall have full authority to have recourse to or enforce this Security in preference to any other guarantee or Security which the Employer may have or obtain and no forbearance on the part of the Employer in enforcing or requiring enforcement of any other Security shall have the effect of releasing the Bank from its full liability hereunder.
- 10 It shall not be necessary for the Employer to proceed against the said Contractor before proceeding against the Bank and the Guarantee herein contained shall be enforceable against the Bank notwithstanding that any Security which The Employer may have obtained or obtain from the Contractor shall at the time when proceedings are taken against the said bank hereunder be outstanding or unrealized.
- 11 We, the said Bank undertake not to revoke this guarantee during its currency except with the consent of the Employer in writing and agree that any change in the constitution of the said Contractor or the said bank shall not discharge our liability hereunder.
- 12 We _____ the said Bank further that we shall pay forthwith the amount stated in the notice of demand notwithstanding any dispute/difference pending between the parties before the arbitrator and/or that any dispute is being referred to arbitration.
- 13 Notwithstanding anything contained herein above, our liability under this guarantee shall be restricted to Rs. _____ (Rupees _____) and this guarantee shall remain in force till _____ and unless a claim is made on us within 3 months from that date, that is before _____ all the claims under this guarantee shall be forfeited and we shall be relieved of and discharged from our liabilities there under.

Dated _____ day of _____ 20

For and on behalf of Bank.

Issued under seal

SPECIAL CONDITIONS OF CONTRACT

1. GENERAL

- 1.1 Wherever any reference to any Indian Standard Specifications of BIS or other International standards of ASTM/BS/EN occurs in the documents relating to this contract, the same shall be inclusive of all amendments issued there-to or revisions thereof, if any, up to the date of receipt of tenders.
- 1.2 The contractor shall work according to the programme of work as approved by the Engineer-in-charge, for which purpose, the contractor shall submit a programme of the work within 07 days from the stipulated date of start of the work based on computer software and shall update the same every fortnight.
- 1.3 The contractor shall take instructions from the Engineer-in-charge for stacking of materials at site. No excavated earth or building materials shall be stacked on areas where the buildings, roads, services or compound walls are to be constructed.
- 1.4 If as per Municipal or prevailing rules of the secured campuses owned by paramilitary forces, Institutions etc, the huts for labour are not to be erected at the site of work by the contractors, the contractors shall provide such accommodation at such locations as are acceptable to local bodies with all provisions concerning labour safety & sanitation as contained in the relevant clause of the contract, for which nothing shall be payable.
- 1.5 Unless otherwise provided in the Schedule of quantities, the rates tendered by the contractor shall be all inclusive and shall apply to all heights, lifts, leads and depths of the building and nothing shall be payable to him on this account.
- 1.6 The working drawings appearing at para 8.1(iii) of conditions of contract in the form CPWD-7/8, shall mean to include both architectural and structural drawings respectively. The structural and architectural drawings shall be properly correlated before executing the work. In case of any difference noticed between architectural and structural drawings, final decision, in writing of the Engineer-in-charge shall be obtained by the contractor before proceeding further.
- 1.7 Some restrictions may be imposed by the security staff etc. on the working and for movement of labour, materials etc. The contractor shall be bound to follow all such restriction / instructions including issue of identity cards to all persons authorized by him to do work / visit the work site and nothing shall be payable on this account.
- 1.8 The contractor shall make his own arrangements for obtaining electric connections, if required, and make necessary payments directly to the department concerned.
- 1.9 The contractor shall conduct his work, so as not to interfere with or hinder the progress or completion of the work being performed by other contractor (s) or by the Engineer-in-Charge and shall as far as possible arrange his work and shall place and dispose off the materials being used or removed, so as not to interfere with the operations of other contractors, or he shall arrange his work with that of the others in an acceptable and coordinated manner and shall perform it in proper sequence to the complete satisfaction of Engineer-in-Charge. The contractor shall be responsible for any damage due to hindrance caused by him.
- 1.10 Cast iron pipes and fittings without ear shall be used. However, pipes and fittings with ears may be accepted without any extra payment. In such cases, clamps are not required and no extra payment shall be made for fixing the pipes in a different manner.
- 1.11 Any cement slurry added over base surface for bond or for continuation of concreting, for protecting reinforcement bars, its cost shall be deemed to have been included in the

respective items, unless specified otherwise and nothing extra shall be payable nor extra cement shall be considered in the cement consumption on this account.

- 1.12 Stacking of materials and excavated earth including its disposal shall be done as per the directions of the Engineer-in-Charge. Double handling of materials or excavated earth if required at any stage shall have to be done by the contractor at his own cost.
 - 1.13 No claim for idle establishment & labour, machinery & equipments, tools & plants and the like, for any reason whatsoever, shall be admissible during the execution of work as well as after its completion.
 - 1.14 Only Star headed Stainless Steel screws shall be used unless otherwise specified.
 - 1.15 Work shall be carried out in professional manner with finished product serving the intended purpose with specified strength, durability and aesthetics.
 - 1.16 Work activities shall be executed in well thought out sequences such that consequent activities not adversely affecting previously done work. Nothing extra shall be payable to protect the works already done.
 - 1.17 The contractor shall prepare all the needed shop drawings well in advance and get them approved before placing the order and execution of the item.
 - 1.18 The contractor shall, at his risk and cost, make all arrangements and shall provide all facilities as the Engineer-in-Charge may require for collecting, and preparing the required number of samples for such tests at such time and to such place or places as may be directed by the Engineer - in -Charge and bear all charges and cost of testing unless specifically provided for otherwise elsewhere in the contract or specifications.
 - 1.19 Agency shall obtain Statutory Approvals from the local bodies (such as CSEB department, Central electricity authority, environment department etc.) on behalf of AIIMS, RAIPUR if any required. AIIMS shall provide necessary assistance and documents. Statutory fee if any shall be paid by the contractor. Nothing extra shall be payable on this account.
 - 1.20 The agency has to provide Annual Maintenance for a period of 5 years; however, AIIMS Raipur reserves the right to terminate the AMC by giving 15 day notice at any time during the Contract period if the services of the Contractor are not satisfactory in the opinion of the AIIMS Raipur or if AIIMS desire to adopt AMC/CAMS/O&M of total electrical system (i.e. Already installed/ existing electrical system and work executed in this tender/ agreement) through single agreement.
 - 1.21 The AMC is based on the manpower basis therefore during 1st year of AMC period (i.e. DLP cum AMC) if any material is required to/for attend breakdown, trouble shooting and Preventive/corrective/predictive maintenance etc. shall be provided by Agency. Thereafter from 2nd year, manning will be provided by agency and if any material is required shall be provided by AIIMS or reimbursed to agency on actual basis but throughout the agreement, Tools and plant required for work will be under the scope of Agency.
- 1.22 Work execution shall be carried out by an electrical contractor licensed in this behalf to comply with The Indian Electricity Rules, 1956 & Electricity act 2010.**

2. RATES

- 2.1 The rates quoted by the Contractor are deemed to be inclusive of site clearance, setting out work, profile, setting lay out on ground, establishment of reference bench mark(s), installing various signage, taking spot levels, survey with total station, construction of all safety and protection devices, compulsory use of helmet and safety shoes, and other

appropriate safety gadgets by workers, imparting continuous training for all the workers, barriers, preparatory works, construction of clean, hygienic and well ventilated workers housings in sufficient numbers as per drawing supplied by Engineer in charge, working during monsoon or odd season, working beyond normal hours, working at all depths, height, lead, lift, levels and location etc. and any other unforeseen but essential incidental works required to complete this work. Nothing extra shall be payable on this account and no extension of time for completion of work shall be granted on these accounts.

- 2.2 The rates quoted by the bidder, shall be firm and inclusive of all taxes and levies.
- 2.3 No foreign exchange shall be made available by the Department for importing (purchase) of equipment, plants, machinery, materials of any kind or any other items required to be carried out during execution of the work. No delay and no claim of any kind shall be entertained from the Contractor, on account of variation in the foreign exchange rate.
- 2.4 All ancillary and incidental facilities required for execution of work like labour camp, stores, fabrication yard, offices for Contractor, watch and ward, temporary ramp required to be made for working at the basement level, temporary structure for plants and machineries, water storage tanks, installation and consumption charges of temporary electricity, telephone, water etc. required for execution of the work, liaison and pursuing for obtaining various No Objection Certificates, completion certificates from local bodies etc., protection works, testing facilities / laboratory at site of work, facilities for all field tests and for taking samples etc. during execution or any other activity which is necessary (for execution of work and as directed by Engineer-in-Charge), shall be deemed to be included in rates quoted by the Contractor, for various items in the schedule of quantities. Nothing extra shall be payable on these accounts. Before start of the work, the Contractor shall submit to the Engineer-in-Charge, a site / construction yard layout, specifying areas for construction, site office, positioning of machinery, material yard, cement & other storage, fabrication yard, site laboratory, water tank etc.
- 2.5 For completing the work in time, the Contractor might be required to work in two or more shifts (including night shifts). No claim whatsoever shall be entertained on this account, not with-standing the fact that the Contractor may have to pay extra amounts for any reason, to the labourers and other staff engaged directly or indirectly on the work according to the provisions of the labour and other statutory bodies regulations and the agreement entered upon by the Contractor with them.
- 2.6 All material shall only be brought at site as per program finalized with the Engineer-in-Charge. Any pre-delivery of the material not required for immediate consumption shall not be accepted and thus not paid for.

3. CLEANLINESS OF SITE

The Contractor shall not stack building material / malba / muck/ rubbish on the land or road of the local development authority or on the land owned by the others, as the case may be. So the muck, rubbish etc. shall be removed periodically as directed by the Engineer-in-Charge, from the site of work to the approved dumping grounds as per the local byelaws and regulations of the concerned authorities and all necessary permissions in this regard from the local bodies shall be obtained by the Contractor. Nothing extra shall be payable on this account. In case, the Contractor is found stacking the building material / malba as stated above, the Contractor shall be liable to pay the stacking charges / penalty as may be levied by the local body or any other authority and also to face penal action as per the rules, regulations and bye-laws of such body or authority. The Engineer –in-Charge shall be at liberty to recover, such sums due but not paid to the concerned authorities on the above counts, from any sums due to the Contractor including amount of the Security Deposit and

performance guarantee in respect of this contract agreement.

4. INSPECTION OF WORK

In addition to the provisions of relevant clauses of the contract, the work shall also be open to inspection by the Engineer-In-Charge, AIIMS Raipur and other senior officers of AIIMS Raipur and his authorized representative. The contractor shall at times during the usual working hours and at all times at which reasonable notices of the intention of the Engineer-in-Charge or other officers as stated above to visit the works shall have been given to the Contractor, either himself be present to receive the orders and instructions or have a responsible Site Engineer duly accredited in writing, to be present for that purpose Senior Officers of AIIMS Raipur Authorities shall also be inspecting the on-going work at site at any time with or without prior intimation.

5. CO-OPERATION WITH OTHER CONTRACTORS/SPECIALIZED AGENCIES/SUB-CONTRACTORS

5.1 The Contractor shall take all necessary precautions to prevent any nuisance or inconvenience to the owners, tenants or occupants of the adjacent properties and to the public in general. The Contractor shall take all care, as not to damage any other adjacent property or other services running adjacent to the plot. If any damage is done, the same shall be made good by the Contractor at his own cost and to the entire satisfaction of the Engineer-in-Charge. The Contractor shall use such methodology and equipment's for execution of the work, so as to cause minimum environmental pollution of any kind during construction. Further, the Contractor shall take all precautions to abide by the environmental related restrictions imposed by Madhya Pradesh Pollution control board, Govt. of Madhya Pradesh.

Utmost care shall be taken to keep the noise level to the barest minimum so that no disturbance as far as possible is caused to the occupants / users of adjoining buildings. No claim what so ever on account of site constraints mentioned above or any other site constraints, inadequate availability of skilled, semi-skilled or unskilled workers in the near vicinity, non-availability of construction machinery spare parts and any other constraints not specifically stated here, shall be entertained from the Contractor. Therefore, the Tenderers are advised to visit site and get first-hand information of site constraints. Accordingly, they should quote their tenders. Nothing extra shall be payable on this account.

5.2 The Contractor shall cooperate with and provide the facilities to the sub-Contractors and other agencies working at site for smooth execution of the work. The contractor shall indemnify STC, BSF, authorities.

Against any claim(s) arising out of such disputes. The Contractor shall:

- (i) Allow use of scaffolding, toilets, sheds etc.
- (ii) Properly co-ordinate their work with the work of other Contractors.
- (iii) Provide control lines and benchmarks to his Sub-Contractors and the other Contractors.
- (iv) Provide electricity and water at mutually agreed rates.
- (v) Provide hoist and crane facilities for lifting material at mutually agreed rates.
- (vi) Co-ordinate with other Contractors for leaving inserts, making chases, alignment of services etc. at site.
- (vii) Adjust work schedule and site activities in consultation with the Engineer-in-Charge and other Contractors to suit the overall schedule completion.

(viii) Resolve the disputes with other Contractors/ sub-contractors amicably and the Engineer-in-Charge shall not be made intermediary or arbitrator.

- 5.3 The work should be planned in a systematic manner so as to ensure proper co-ordination of various disciplines viz. sanitary & water supply, drainage, rain water harvesting, electrical, firefighting, information technology, communication & electronics and any other services.
- 5.4 Other agencies will also simultaneously execute and install the works of sub-station / generating sets, air-conditioning, lifts, etc. for the work and the contractor shall afford necessary facilities for the same. The contractor shall leave such recesses, holes, openings trenches etc. as may be required for such related works (for which inserts, sleeves, brackets, conduits, base plates, clamps etc. shall be supplied free of cost by the department unless otherwise specifically mentioned) and the contractor shall fix the same at time of casting of concrete, stone work and brick work, if required, and nothing extra shall be payable on this account.
- 5.5 The contractor shall conduct his work, so as not to interfere with or hinder the progress or completion of the work being performed by other contractor(s) or by the Engineer-in-Charge and shall as far as possible arrange his work and shall place and dispose off the materials being used or removed so as not to interfere with the operations of other contractor or he shall arrange his work with that of the others in an acceptable and in a proper co-ordinate manner and shall perform it in proper sequence to the complete satisfaction of others.

6. SAFETY MEASURES AT CONSTRUCTION SITE

In order to ensure safe construction, following shall be adhered for strict compliance at the site:-

- (i) The work site shall be properly barricaded.
- (ii) Adequate singnages indicating 'Work in Progress – Inconvenience caused is Regretted' or Diversion Signs shall be put on the sites conspicuously visible to the public even during night hours. These are extremely essential where works are carried out at public places in use by the public.
- (iii) The construction malba at site shall be regularly removed on daily basis.
- (iv) All field officials and the workers must be provided with safety helmets, safety shoes and safety belts.
- (v) Proper MS pipe scaffoldings with work – platforms and easy-access ladders shall be provided at site to avoid accidents.

Necessary First-Aid kit shall be available at the site.

The above provisions shall be followed in addition to the provisions of General Condition of Contract.

7. FIELD TESTING INSTRUMENTS

(Following instruments in sufficient quantity as directed by the Engineer- in- Charge shall be made available by the contractor. It shall be ensured that the instruments always remain in serviceable condition else the same will be replaced. In case of non-availability of instrument Engineer-In-Charge will purchase the same and the invoice amount will be deducted from the bill and will be bound to contractor in the interest of work.

- (1) Steel tapes – 3 m / 5m / 7.5m / 15m / 30m
- (2) Vernier Calipers.
- (3) Micrometer screw 25 mm gauge.
- (4) A good quality plumb bob.
- (5) Spirit level, minimum 30 cms long with 3 bubbles for horizontal vertical.
- (6) Wire gauge (circular type) disc.
- (7) Foot rule.
- (8) Long nylon thread.
- (9) Rebound hammer for testing concrete
- (10) Dynamic penetrometer.
- (11) Magnifying glass
- (12) Screw driver 30 cms long
- (13) Ball pin hammer, 100 gms.
- (14) Plastic bags for taking samples
- (15) Moisture meter for timber
- (16) Earth resistance tests
- (17) Total station
- (18) Multimeter,
- (19) Meggar
- (20) Refrigerant Leak detector
- (21) Pipe Bender
- (22) Thermometer
- (23) Hygrometer
- (24) CFM Meter
- (25) Step Ladder
- (26) Cordless drill

8. THE CONTRACTOR SHALL SUBMIT 'METHOD STATEMENT' FOR THE APPROVAL SOON AFTER THE AWARD OF WORK

'Method Statement' is a statement by which the construction procedures for important activities of construction are stated, checked and approved. Method Statement shall have description of the item with elaborate procedures in steps to implement the same. The specification of the materials involved their testing and acceptance criteria, equipments to be used, precautions to be taken, mode of measurements etc.

9. TESTING OF MATERIALS

- 9.1 The contractor shall arrange carrying out of all tests required under the agreement through the laboratory as approved by the Engineer-in-Charge and shall bear all charges in connection therewith including fee for testing unless specified otherwise. In all cases cost of samples and to & fro carriage shall be borne by the contractor. Contractor shall establish a laboratory at site of work at his own cost. The laboratory shall be equipped with all necessary equipment as per requirement of specification or as per direction of Engineer-in-Charge. A list of laboratory equipment to be maintained by the contractor is enclosed at Para 13 page 40 & 41. Establishing the laboratory at site shall not absolve the contractor from fulfilling the criteria of getting the test done in independent approved laboratories as per DG, CPWD, O.M. No. DG/MAN/308 dated 29.05.2014. The decision of the Engineer-in-Charge of allowing any test in the site laboratory shall be final.
- 9.2 Even ISI marked materials may be subjected to quality test at the discretion of the Engineer-in-Charge besides testing of other materials as per the specifications described

for the item/material. Whenever ISI marked materials are brought to the site of work the contractor shall, if required by the Engineer-in-Charge, furnish manufacturer test certificate or test certificate from approved testing laboratory to establish that the material procured by the contractor for incorporation in the work satisfy the provisions of IS codes relevant to the material and/or the work done.

- 9.3 Substandard Material/Work: In case any material/work is found substandard the same shall be rejected by the Engineer-in-Charge and the same shall be removed from the site of work within 48 hour, failing which the same shall be got removed by the Engineer-in-Charge at the risk and cost of the contractor without giving any further notice and time.



FORM OF APPLICATION BY THE CONTRACTOR FOR SEEKING EXTENSION OF TIME

(PART – I)

1. Name of contractor
2. Name of work as given in the agreement
3. Agreement no.
4. Estimated amount put tender
5. Date of commencement of work as per agreement
6. Period allowed for completion of work as per agreement
7. Date of completion stipulated in agreement
8. Period for which extension of time has been given previously:

	EE's letter no. and date	Extension granted	
		Months	Days
(a) 1st extension			
(b) 2nd extension			
(c) 3rd extension			
d) 4th extension			
(e) Total extension previously given.....			

9. Reasons for which extension have been previously given (copies of the previous applications should be attached)
10. Period for which extension if applied for
11. Hindrances on account of which extension is applied for with dates on which hindrances occurred and the period for which these are likely to last.

Serial no	Nature of hindrance	Date of occurrence	Period for which it is likely to last	Period for which extension required for this particular hindrance	Overlapping period if any, with reference to item.	Net extension applied for	Remarks, if any
a	b	c	d	e	f	g	h

Total period on account of hindrances mentioned above..... Months Days

12. Extension of time required for extra work.
13. Details of extra work and the amount involved:
 - a. Total value of extra work
 - b. Proportionate period of extension of time based on estimated amount put to tender on account of extra work.

14. Total extension of time required for 11 & 12 Submitted to the Sub Divisional Officer
.....

Signature of contractor
Dated:.....

FORM OF APPLICATION OF THE CONTRACTOR FOR SEEKING RESCHEDULING OF THE MILESTONES

1. Name of contractor

2. Name of work as given in the agreement

3. Agreement no.

4. Estimated amount put tender

5. Date of commencement of work as per agreement

6. Period allowed for completion of work as per agreement

7. Date of completion stipulated in agreement

8. Rescheduling of milestones done previously

Milestone No. Already Rescheduled	EE's Letter No. and Date	Rescheduling Of Milestones Done	
		Original Date	Rescheduled Date
(A) 1st Milestone			
(B) 2nd Milestone			

Rescheduling of milestone applied for

Milestone No. For Which Rescheduling is Applied	Original/ Rescheduled Date	Details And Period of Hindrances	Comments of Executive Engineer	Proposed Rescheduled Date of
(A) 1st Milestone				
(B) 2nd Milestone				

Submitted to the Sub Divisional Officer

Signature of Contractor

Dated

**GUARANTEE BOND TO BE EXECUTED BY CONTRACTORS FOR REMOVAL OF DEFECTS
AFTER COMPLETION IN RESPECT OF WATER PROOFING WORKS**

The Agreement made this day of two thousand and between son of of (hereinafter called the Guarantor of the one part) and the PRESIDENT OF INDIA (hereinafter called Government of the other part).

WHEREAS this agreement is supplementary to a contract (hereinafter called the Contract) dated and made between the GUARANTOR of the one part and the Government of the other part, whereby the Contractor, inter alia, undertook to render the buildings and structures in the said contract recited completely water and leak-proof.

AND WHEREAS GUARANTOR agreed to give a guarantee to the effect that the said structures will remain water and leak-proof for five years from the date of giving of water proofing treatment.

NOW THE GUARANTOR hereby guarantees that water proofing treatment given by him will render the structures completely leak-proof and the minimum life of such water proofing treatment shall be five years to be reckoned from the date after the maintenance period prescribed in the contract.

Provided that the guarantor will not be responsible for leakage caused by earthquake or structural defects or misuse of roof or alteration and for such purpose:

- (a) Misuse of roof shall mean any operation which will damage proofing treatment, like chopping of firewood and things of the same nature which might cause damage to the roof;
- (b) Alteration shall mean construction of an additional storey or a part of the roof or construction adjoining to existing roof whereby proofing treatment is removed in parts;
- (c) The decision of the Engineer-in-Charge with regard to cause of leakage shall be final.

During this period of guarantee the guarantor shall make good all defects and in case of any defect being found, render the building water-proof to the satisfaction of the Engineer-in-Charge at his cost, and shall commence the work for such rectification within seven days from the date of issue of the notice from the Engineer-in-Charge calling upon him to rectify the defects, failing which the work shall be got done by the Department by some other contractor at the GUARANTOR'S cost and risk. The decision of the Engineer- in-Charge as to the cost, payable by the Guarantor shall be final and binding.

That if GUARANTOR fails to execute the water proofing or commits breach thereunder then the GUARANTOR will indemnify the Principal and his successors against all loss, damage, cost, expense or otherwise which may be incurred by him by reason of any default on the part of the GUARANTOR in performance and observance of this supplementary agreement. As to the amount of loss and/or damage and/or cost incurred by the Government the decision of the Engineer-in-Charge will be final and binding on the parties.

IN WITNESS WHEREOF these presents have been executed by the Obligorand by and for and on behalf of the PRESIDENT OF INDIA on the day, month and year first above written.

Signed, sealed and delivered by OBLIGOR in the presence of

- 1.
- 2.

Signed for and on behalf of THE PRESIDENT OF INDIA by in the presence of

- 1.

LIST OF SPECIALIZED ITEMS / JOBS

List I - Civil Works

1. ** Water proofing treatment work.
2. Steel work in steel bridge work, space frames for long span structures, steel towers.
3. ** Special foundations including all types of piles.
4. RCC Overhead Tank with independent staging.
5. Structural Repair and Rehabilitation/ Retrofitting works.
6. Soil Investigation and Survey Work.
7. ** Facade cleaning system and façade cleaning.
8. Custom made wooden furniture (factory made).
9. Diaphragm walls.
10. Post construction Anti-termite chemical treatment.
11. Water Treatment Plants
12. Security to vacant bungalows/premises.
13. Tentage works.
14. Washing/dry cleaning works.
15. Synthetic play area surface for games.
16. Electronic / Digital Signages.
17. Environment Impact Assessment Study and Environment Clearance.
18. Mechanized Housekeeping Work .

Note:

**For these works, Specialized Agencies shall have to be associated by the duly approved specialized agency by Engineer-In-Charge in case the Contractor does not possess the requisite eligibility and experience as per the NIT conditions to carry out these works..

Electrical Works

LIST- II (A)

S. No. Supplying /fabrication, installation, testing and commissioning of the following

1. Kitchen equipment
2. Lifts, escalators and conveyors
3. Simultaneous interpretation systems
4. Gas plants.
5. Cold storage plant
6. Hot Water/Steam Boilers
7. Public address system; conferencing system, automatic vote recording system, recorders
8. Stage lighting
9. Projector and other special equipment for theatre
10. Repairs and calibration of various types of measuring instruments and relays etc.
11. Testing of transformer oil and dehydration and other type of high potential test.
12. Frequency Convertor
13. Temporary illumination, security lighting and wiring for power outlets for metal detectors in connection with Republic Day and Independence Day Celebrations.
14. EPBAX system (equipments).
15. EPBAX system (cabling and wiring).
16. Illumination of heritage caves and fiber optic lighting system
17. Security system and alarm
18. Building Automation System
19. Hydraulic platform /Lift
20. Incinerator
21. Laundry equipment
22. Centralized clock system.
23. Interior/exterior flood lighting of heritage/Monumental buildings/structures involving Computer aided design and evolution of special mounting arrangements for luminaries:

24. Gas pipe line
25. Modular OT
26. Electrically Operated Gate
27. Fountain Work
28. Water supply motors and pumps of 100 hp or more
29. Mechanized Car Parking Systems
30. VRV/VRF Type Air-Conditioning Systems
31. Oxygen Generation Plant
32. CCTV and Allied Equipments
33. Access Control System
34. Hydro Pneumatic Pumps
35. Providing and fixing of Sensor operated Gates
36. Precision Air Conditioning System
37. LAN System
38. SITC of active power factor filter
39. SITC of Solar Photo Voltaic Power generation system

LIST-II (B)

S. No. Supplying /fabrication, installation, testing and commissioning of the following

1. Diesel Generating Set
2. Heating, Ventilation and Air-conditioning System
3. Sub-station equipment
4. Fire fighting system (including wet riser and sprinkler system, portable fire extinguishers)
5. Fire detection and alarm system

List -III Horticulture Works

(1) Construction of Vertical Green Wall.

LIST -IV Concurrent list of specialized items/ jobs

(1) Sewage Treatment Plant

(2) Outsourcing of Day to Day Maintenance Work*

*Note :

(a) For Outsourcing of Day to Day Maintenance Work, Provision is to be made in the NIT for specialized agency duly approved by Engineer-In-Charge, not having the requisite eligibility and experience as per the NIT conditions, to execute the Comprehensive Maintenance Work by associating Agencies Specialized in Day to Day Maintenance Work.

(b) Outsourcing of Day to Day Maintenance Work is the "Specialized Work" for the purpose of association only and not for awarding work on standalone basis.

NO CLAIM CERTIFICATE

(On company letterhead)

To,

The Executive Engineer,

Project Cell, AIIMS, Raipur

Name of Work-

Agreement No. -

Sub: No claim declaration / certificate

We have received the sum of Rs. (Rupees only) in full and final settlement of all the payments due to us for the above stated work under the above mentioned contract agreement, between us and AIIMS, Raipur. We hereby unconditionally, and without any reservation whatsoever, certify that with this payment, we shall have no claim whatsoever, of any description, on any account, against Procuring Entity, against aforesaid contract agreement executed by us. We further declare unequivocally, that with this payment, we have received all the amounts payable to us, and have no dispute of any description whatsoever, regarding the amounts worked out as payable to us and received by us, and that we shall continue to be bound by the terms and conditions of the contract agreement, as regards performance of the contract.

Yours faithfully,

Signatures of contractor

or Officer authorised to sign the contract documents

on behalf of the contractor

(Company stamp)

Date:

Place:

APPROVED MATERIALS LIST (ELECTRICAL)

1. Unless otherwise specified, the brand/make of the material as specified in the item nomenclature or in the particular specifications or in the list of approved materials attached in the tender shall be used in the work.
2. The Contractor shall obtain prior approval from the Engineer-in-charge before placing order for any specific material/ Brand/ Make.
3. Whenever the specified brand of material is not available then, the Engineer-in-charge may approve any material equivalent to that specified subject to proof being offered by the Contractor for its equivalence and its non-availability to his satisfaction.

The following are the acceptable makes of Electrical materials as indicated against individual items:

Sl. No.	Item	Acceptable Makes
1	LT Panels	Siemens / L & T/ Schneider/ C & S/ ABB Note: LT Panels from Licensed partners of Original equipment manufacturer -Siemens / L&T/ Schneider/ C & S/ ABB who are authorized to fabricate LT panel as per design, drawing of OEM are also acceptable. The LT panel shall bear Logo of OEM.
2	Cables	Finolex / CCI/ RR Cables/ Universal/ Polycab
3	MCCB	L&T/ Siemens/ Schneider/ ABB/ GE Alstom/ C&S Electric
4	Change over Box	Siemens / L & T/ C&S / GE / ABB/ Schneider
5	PVC insulated Copper wire / Telephone wire / Control wire	Finolex / HAVELLS / KEI / RR Kabel / Polycab / Anchor (All with ISI Marked)
6	MCB / MCB Prewired DB / RCCB/ Industrial Socket not less than 10 K.	L&T/ Siemens/ Schneider/ ABB/ GE Alstom/ C&S Electric/ Legrand
7	Selector Switches	L&T/ Salzer/ Kaycee/ Siemens/ BCH/ Schneider/ Veshno/ Teknik/ RAAS
9	Current. Transformer	L&T/ A.E./ Kappa/ IMP/ GE/ Siemens / L & T/ Schneider/ C & S/ ABB
10	Indication Lamp (LED type)	Binoy /Essen/ Siemens/ B.C.H/ L&T/ Altos
11	Ammeters / volt meter (Digital type)	AEI/ IMP/ MECO/ Rishab / Yokins/ L&T/ Schneider
12	Power/auxiliary contactors, timers, Relay, Starters.	Siemens / L & T/ Schneider/ C & S/ ABB
13	LUGS, Thimble, Cable Glands	Dowells/ Comet/ Hex/ Jhonson / Gripwell/ Combat/ Raychem
14	Tap-off Box (Plug in Type), End Feed Unit	C&S Electric & Switchgear, L & T, ABB, Siemens, Schneider, Tricolite

15	Electrical grade Aluminium Bus bar	Hindalco, Nalco
16	Cable tray	Profab, OBO, MK, Indiana
17	HRC Protection Fuses/ Fuse Fittings.	Siemens / L & T/ Schneider/ C & S/ ABB
18	PVC Conduit	BEC / AKG / MK / Anchor / Finolex / Steel Craft / Saraswati /Swastik/Polycab
19	Casing Caping	Saraswati / Polycab / Precision / Astral
20	Brass Batten / Angle Holder.	Kinjal / Antex / Emperor/ Havells/ Bajaj
21	Modular Switch / Socket / Blanking Plate /PVC Box / Metal (GI)Switch Box (the gauge of GI Box shall not less than 16 SWG/1.2mm, depth \geq 60mm & of the same make that of Switch) Front Plates, Telephone, T.V. Outlets Socket / Fan Regulator.	Crabtree (Verona), Anchor (Vision), L&T(Entice), MK (Citric), Legrand (Myrius), Schneider (Opale), Siemens.
22	LED Light fitting	Wipro/ Philips/ Bajaj/ Crompton/ Havells/ Halonix.
23	Timer	L&T/ Siemens/ Schinder/ Hager/ Legrand
24	G.I. Pipe	Jindal/ Tata/ Prakash/Surya
25	MPCB	L&T, ABB, Siemens, Schneider
26	Battery	Exide/ Panasonic/ Hitachi/ Cummins/ Amaron

PROFORMA OF SCHEDULES (ELECTRICAL)**SCHEDULE 'A'**

Schedule of quantities : **(Attached in e-procurement site)**

SCHEDULE 'D'

Extra schedule for specific requirements/
document for the work, if any. : **Nil**

SCHEDULE 'E'

Reference to General Conditions of contract : CPWD General Conditions of Contract 2019 (Maintenance) modified and amendment up to the last date of submission of tender.

Name of work : **"Augmentation of Existing Electrical Distribution system for Phase- 1 (In Substation- 2, 3, 4 and Hospital Block) at AIIMS Raipur"**

Estimated cost of work : **Rs 2,29,97,589.00/-**
(i) Earnest money : **EMD Declaration Form (As per Annexure-H)**

(ii) Performance Guarantee : 3% of tendered value.

(iii) Security Deposit : 2.5% of tendered value.

SCHEDULE 'F'**GENERAL RULES & DIRECTIONS:**

Officer inviting tender : **Executive Engineer (Civil), AIIMS Raipur on behalf of Director AIIMS Raipur.**

Maximum percentage for quantity of items of work to be executed beyond which rates are to be determined in accordance with Clauses 12.2 & 12.3. : See below

Definitions:

2(v) Engineer-in-Charge : **Superintending Engineer, AIIMS Raipur (C.G)**

2(viii) Accepting Authority : **Executive Engineer, AIIMS Raipur (C.G)**

2(x) Percentage on cost of materials and labour to cover all overheads and profits. : **15%**

2(xi) Standard Schedule of Rates : **As per DSR 2018 (E&M) (up to date of submission of NIT) & Market Rates**

- 2(xii) Department** : **Project Cell, AIIMS Raipur.**
- 9(ii) Standard CPWD contract Form** : **GCC 2019 & CPWD Form-8 as modified & corrected up to last date of receipt of Bid/tender.**

CLAUSE 1

(i) Time allowed for submission of Performance Guarantee : **07 Days**

(ii) Maximum allowable extension with late fee @ 0.1% per day of Performance Guarantee amount beyond the period Provided in (i) above : **07 Days**

CLAUSE 2

Authority for fixing compensation under clause 2 : Superintending Engineer /Director, AIIMS

Clause 2A

Whether Clause 2A shall be applicable : **No**

CLAUSE 5

Number of days from the date of issue of letter of acceptance for reckoning date of start : **14 Days**

Mile stone(s) as per table given below:-

Sl No	Description of Milestone (Physical)	Time allowed in days (from date of start)	Amount to be withheld in case of non-achievement of
1	Submission of Shop Drawing/samples	30 days	1/3 rd of Contract Value for each milestone.
2	Supply and installation of Electrical panels	210 days	
3	Commissioning of Electrical system	240 days	

Time allowed for execution of work – **240** days.

Authority to decide:

- (i) Extension of time : Executive Engineer, AIIMS Raipur (C.G.)
- (ii) Rescheduling of mile stones : Superintending Engineer/Director, AIIMS Raipur
- (iii) Shifting of date of start in case of delay in handing over of site : Superintending Engineer/Director, AIIMS Raipur

PROFORMA OF SCHEDULES**CLAUSE 5**

Schedule of handing over of site

Part	Portion of Site	Description	Time Period for handing over reckoned from date of issue of letter of Intent.
Part A	Portion without any hindrance	All works	14 days
Part B	Portions with encumbrances	NA	NA
Part C	Portions dependent on work of other agencies	NA	NA

Applicable clause 5/ Clause 5A : 5A (Not Applicable)

CLAUSE 7

Gross work to be done together with net payment /adjustment of advances for material collected, if any, since the last such payment for being eligible to interim payment.

Estimate cost put to tender

- : i) Up to Rs. 10 lacs – Nil**
ii) More than Rs. 10 and up to 50 lacs – Rs. 15 lacs
iii) More than Rs. 50 lacs – Rs. 25 lacs

CLAUSE 7 A

No Running Account Bill shall be paid for the work till the applicable labour licenses, registration with EPFO, ESIC and BOCW Welfare Board, whatever applicable are submitted by the contractor to the Engineer-in-Charge.

Whether clause 7A shall be applicable : **yes**

CLAUSE 10A : As required by Engineer-In-Charge

CLAUSE 10B (ii)

Whether Clause 10 B (ii) shall be applicable : **Not Applicable**

CLAUSE 10C

Component of labour expressed as percent of value of work : **Not Applicable**

CLAUSE 10CA : **Not Applicable**

Authority to issue base price of materials

S.N.	Materials Covered Under this clause:	Nearest Materials (other than cement*, reinforcement bars, the structural steel and POL) for which All India Wholesale Price Index to be followed:	Base Price and its corresponding period of all the Materials covered under clause 10 CA*
1	←		
2		NIL	
3			
4			→

* includes Cement component used in RMC brought at site from outside approved RMC plants, if any.

** Base price and its corresponding period of all the materials covered under clause 10 CA is to be mentioned at the time of approval of NIT. In case of recall of tenders, the base price may be modified by adopting latest base price and its corresponding period.

CLAUSE 10CC : **Not Applicable**

Clause 11

Specifications to be followed for execution of work : **CPWD Specifications for Electrical works Part-I (Internal) 2013, Part-II (External) 1994 to Part-VIII 2013 & 2018 - amended upto last date of tender submission. (Electrical & Fire), (if not available with CPWD Specification then BIS).**

CLAUSE 12

Type of Work : **Maintenance Work**

Authority to decide deviation up to 1.5 times of tendered amount : Superintending Engineer, AIIMS Raipur (C.G.)

12.2&12.3

Deviation Limit beyond which clauses 12.2 & 12.3 shall apply for building work : As per CPWD Works Manual-2019

12.5

(i) Deviation Limit beyond which clauses 12.2 & 12.3 shall apply for foundation work (except items mentioned in earth work subhead in DSR and related items) : As per CPWD Works Manual-2019

(ii) Deviation Limit for items mentioned in earth work subhead of DSR and related items : As per CPWD Works Manual-2019

CLAUSE 16

Competent Authority for deciding reduced rates. : Superintending Engineer/ Director, AIIMS Raipur

CLAUSE 18

List of mandatory machinery, tools & plants : As required by Engineer -in- Charge to be deployed by the contractor at site

CLAUSE 19 C..... Engineer- in charge (Executive Engineer)

CLAUSE 19 D..... Engineer- in charge (Executive Engineer)

CLAUSE 19 G Engineer- in charge (Executive Engineer)

CLAUSE 19 K Engineer- in charge (Executive Engineer)

CLAUSE 25

Constitution of Dispute Redressal Committee (DRC): [AIIMS, Raipur](#)

CLAUSE 32

Requirement of Technical Representative(s) and recovery Rate

S No	Minimum Qualification of Technical Representative	Discipline	Designation (Principal Technical / Technical representative)	Minimum experience	Number	Rate at which recovery shall be made from the contractor in the event of not fulfilling provision of Clause 36(i)	
						Figures	Words
1	Graduate Engineer	Electrical	Project Manager cum planning Engineer	2 - years	ONE	Rs. 15,000/- PM	Rupees Fifteen Thousand Per Month each
2	Diploma Engineer	Electrical	Site/ billing Engineer	5-years	ONE	Rs.15000/- PM	Rupees Fifteen Thousand Per Month each

Assistant Engineers retired from Government services that are holding Diploma will be treated at par with Graduate Engineers.

Diploma holder with minimum 10 year relevant experience with a reputed construction co. can be treated at par with Graduate Engineers for the purpose of such deployment subject to the condition that such diploma holders should not exceed 50% of requirement of degree engineers.

CLAUSE 38

:

Not Applicable

Electrical Panel Drawing

TYPE 'A' PANEL

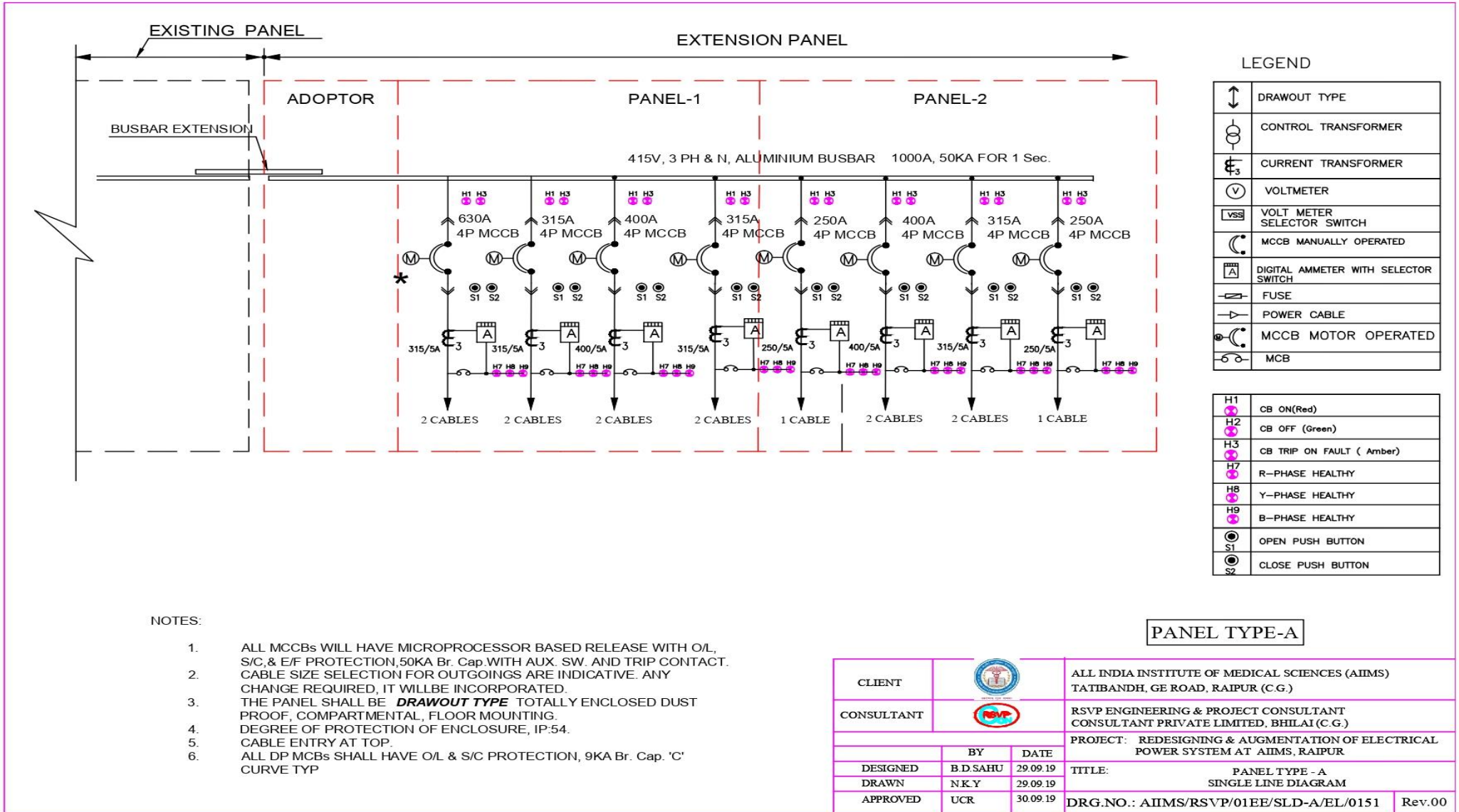

TYPE 'B' PANEL

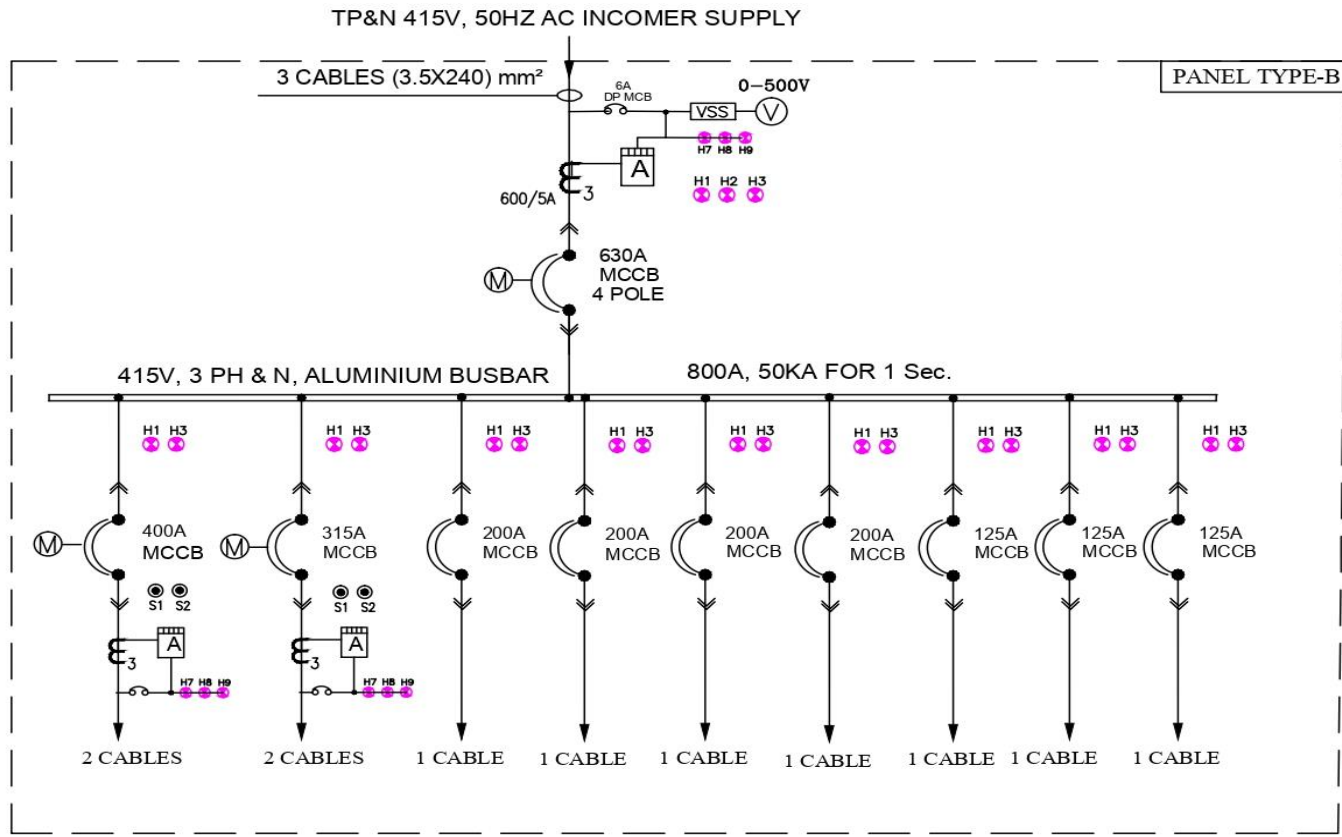

LEGEND

	DRAWOUT TYPE
	CONTROL TRANSFORMER
	CURRENT TRANSFORMER
	VOLTMETER
	VOLT METER SELECTOR SWITCH
	MCCB MANUALLY OPERATED
	DIGITAL AMMETER WITH SELECTOR SWITCH
	FUSE
	POWER CABLE
	MCCB MOTOR OPERATED
	MCB

	CB ON (Red)
	CB OFF (Green)
	CB TRIP ON FAULT (Amber)
	R-PHASE HEALTHY
	Y-PHASE HEALTHY
	B-PHASE HEALTHY
	OPEN PUSH BUTTON
	CLOSE PUSH BUTTON

NOTES:

1. INCOMING MCCBs WILL HAVE MICROPROCESSOR BASED RELEASE WITH O/L, S/C, & E/F PROTECTION, 50KA Br. Cap. WITH AUX. SW. AND TRIP CONTACT.
2. OUTGOING MCCBs WILL HAVE THERMO MAGNETIC RELEASE WITH O/L, S/C PROTECTION, 50KA Br. Cap. WITH AUX. SW. AND TRIP CONTACT.
3. CABLE SIZE SELECTION FOR OUTGOINGS ARE INDICATIVE. ANY CHANGE REQUIRED, IT WILL BE INCORPORATED.
4. THE PANEL SHALL BE **DRAWOUT** TYPE TOTALLY ENCLOSED DUST PROOF, COMPARTMENTAL, FLOOR MOUNTING.
5. DEGREE OF PROTECTION OF ENCLOSURE, IP:54.
6. CABLE ENTRY AT TOP AND BOTTOM.
7. ALL DP MCBs SHALL HAVE O/L & S/C PROTECTION, 9KA Br. Cap. 'C' CURVE TYP

PANEL TYPE-B

CLIENT		ALL INDIA INSTITUTE OF MEDICAL SCIENCES (AIIMS) TATIBANDH, GE ROAD, RAIPUR (C.G.)
CONSULTANT		RSVP ENGINEERING & PROJECT CONSULTANT CONSULTANT PRIVATE LIMITED, BHILAI (C.G.)
PROJECT: REDESIGNING & AUGMENTATION OF ELECTRICAL POWER SYSTEM AT AIIMS, RAIPUR		TITLE: PANEL TYPE - B SINGLE LINE DIAGRAM
DESIGNED	BY B.D SAHU	DATE 29.09.19
DRAWN	N.K.Y	29.09.19
APPROVED	UCR	30.09.19
DRG.NO.: AIIMS/RSVP/01EE/SLD-B/EL/0152		Rev.00

TYPE 'C' PANEL

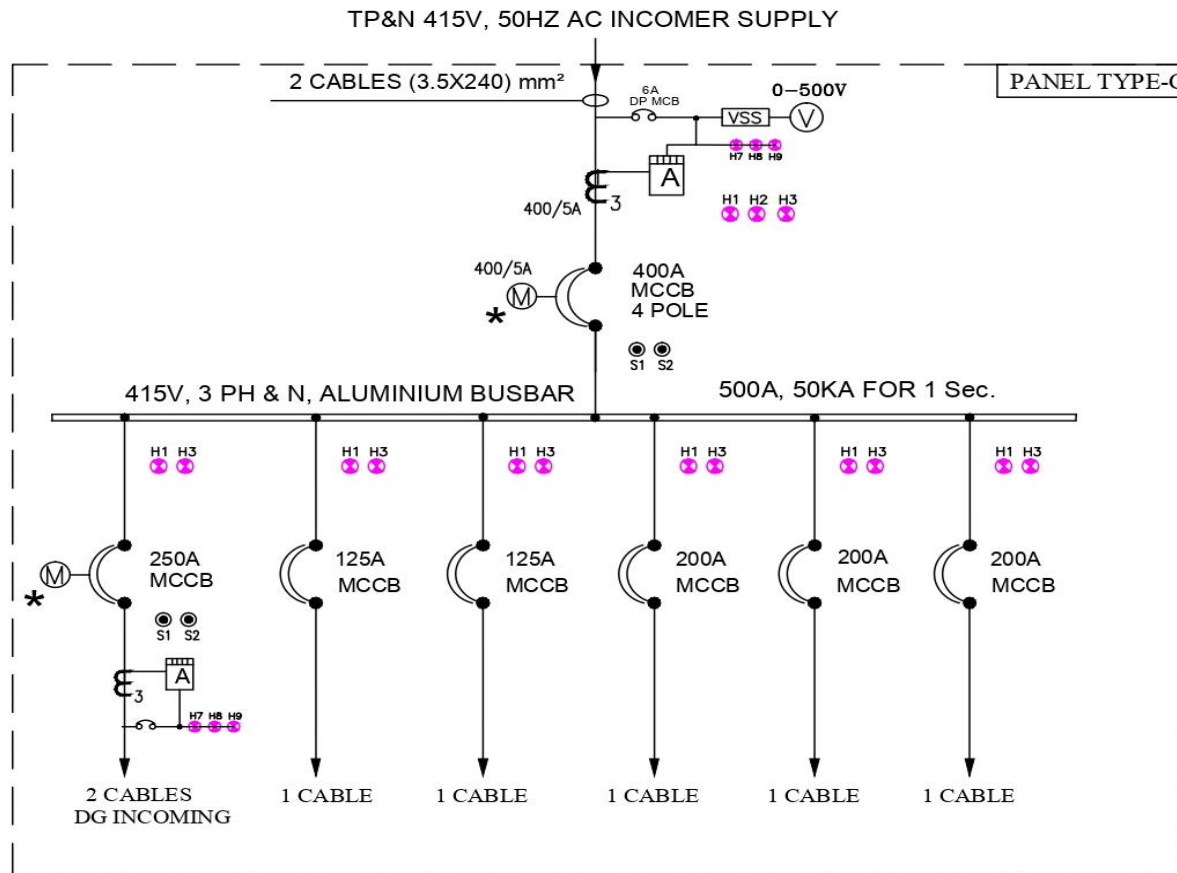

LEGEND

	DRAWOUT TYPE
	CONTROL TRANSFORMER
	CURRENT TRANSFORMER
	VOLTMETER
	VOLT METER SELECTOR SWITCH
	MCCB MANUALLY OPERATED
	DIGITAL AMMETER WITH SELECTOR SWITCH
	FUSE
	POWER CABLE
	MCCB MOTOR OPERATED
	MCB

	CB ON(Red)
	CB OFF (Green)
	CB TRIP ON FAULT (Amber)
	R-PHASE HEALTHY
	Y-PHASE HEALTHY
	B-PHASE HEALTHY
	OPEN PUSH BUTTON
	CLOSE PUSH BUTTON

NOTES:

1. INCOMING MCCBs WILL HAVE MICROPROCESSOR BASED RELEASE WITH O/L, S/C, & E/F PROTECTION, 50KA Br. Cap. WITH AUX. SW. AND TRIP CONTACT.
2. OUTGOING MCCBs WILL HAVE THERMO MAGNETIC RELEASE WITH O/L, S/C PROTECTION, 50KA Br. Cap. WITH AUX. SW. AND TRIP CONTACT.
3. CABLE SIZE SELECTION FOR OUTGOINGS ARE INDICATIVE. ANY CHANGE REQUIRED, IT WILL BE INCORPORATED.
4. THE PANEL SHALL BE **NON DRAWOUT TYPE** TOTALLY ENCLOSED DUST PROOF, COMPARTMENTAL, FLOOR MOUNTING.
5. DEGREE OF PROTECTION OF ENCLOSURE, IP:54.
6. CABLE ENTRY AT TOP AND BOTTOM.
7. ALL DP MCBs SHALL HAVE O/L & S/C PROTECTION, 9KA Br. Cap. 'C' CURVE TYP

* INTERLOCKING BETWEEN INCOMER & 250A BREAKER NOT TO CLOSE SIMULTANEOUSLY

PANEL TYPE-C

CLIENT		ALL INDIA INSTITUTE OF MEDICAL SCIENCES (AIIMS) TATIBANDH, GE ROAD, RAIPUR (C.G.)
CONSULTANT		RSVP ENGINEERING & PROJECT CONSULTANT CONSULTANT PRIVATE LIMITED, BHILAI (C.G.)
		PROJECT: REDESIGNING & AUGMENTATION OF ELECTRICAL POWER SYSTEM AT AIIMS, RAIPUR
	BY	DATE
DESIGNED	B.D.SAHU	29.09.19
DRAWN	N.K.Y	29.09.19
APPROVED	UCR	30.09.19
TITLE:		PANEL TYPE - C SINGLE LINE DIAGRAM
DRG.NO.:		AIIMS/RSVP/01EE/SLD-C/EL/0153
		Rev.00

TYPE 'D' PANEL

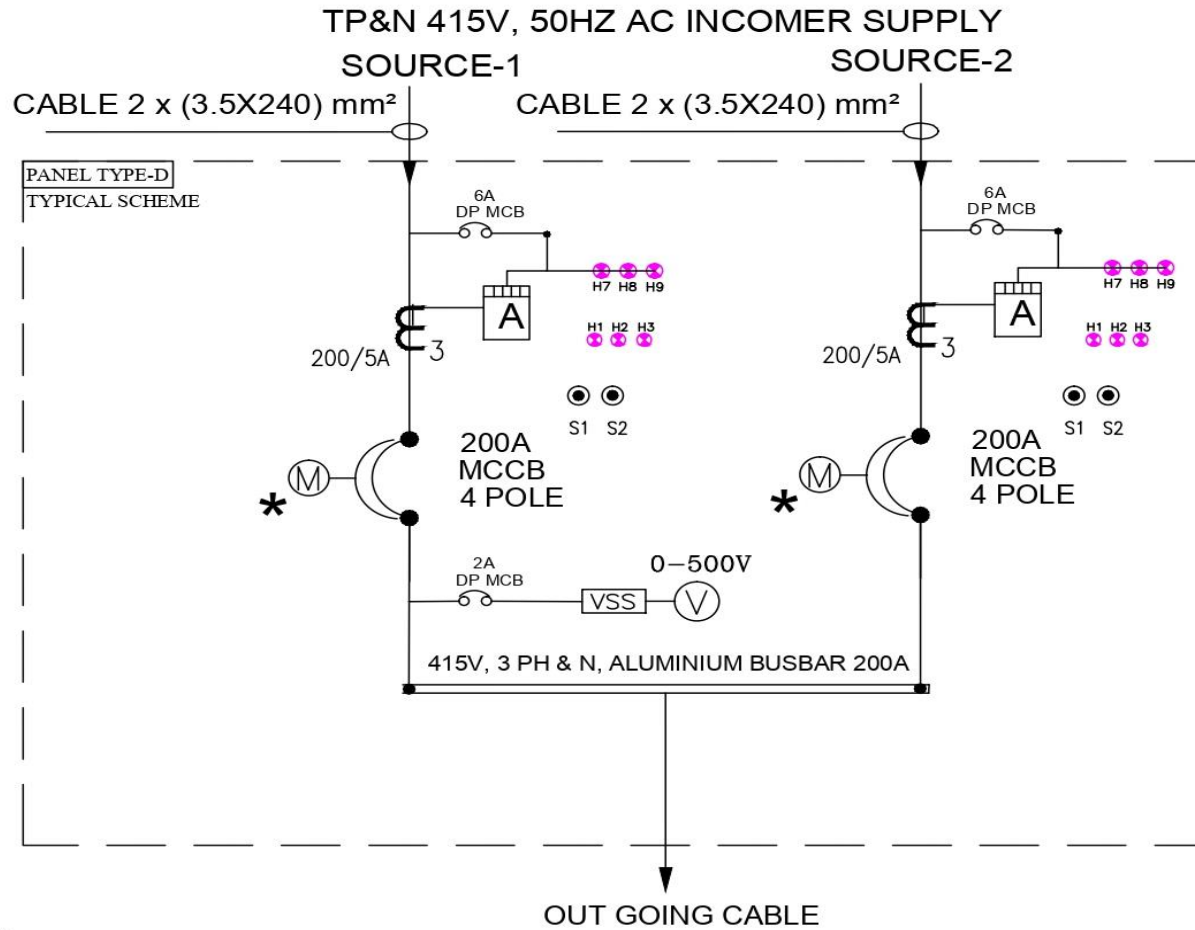

LEGEND

	DRAWOUT TYPE
	CONTROL TRANSFORMER
	CURRENT TRANSFORMER
	VOLTMETER
	VOLT METER SELECTOR SWITCH
	MCCB MANUALLY OPERATED
	DIGITAL AMMETER WITH SELECTOR SWITCH
	FUSE
	POWER CABLE
	MCCB MOTOR OPERATED
	MCB

H1	CB ON (Red)
H2	CB OFF (Green)
H3	CB TRIP ON FAULT (Amber)
H7	R-PHASE HEALTHY
H8	Y-PHASE HEALTHY
H9	B-PHASE HEALTHY
S1	OPEN PUSH BUTTON
S2	CLOSE PUSH BUTTON

NOTES:

- ALL MCCBs WILL HAVE MICROPROCESSOR BASED RELEASE WITH O/L, S/C, & E/F PROTECTION, 50KA Br. Cap. WITH AUX. SW. AND TRIP CONTACT.
 - THE PANEL SHALL BE **NON DRAWOUT TYPE** TOTALLY ENCLOSED DUST PROOF, FLOOR MOUNTING.
 - DEGREE OF PROTECTION OF ENCLOSURE, IP:54.
 - CABLE ENTRY AT TOP AND BOTTOM.
 - ALL DP MCBs SHALL HAVE O/L & S/C PROTECTION, 9KA Br. Cap. 'C' CURVE TYP
- * INTERLOCKING BETWEEN BOTH INCOMER WITH AUTO CHANGEOVER SCHEME.

PANEL TYPE-D

CLIENT		ALL INDIA INSTITUTE OF MEDICAL SCIENCES (AIIMS) TATIBANDH, GE ROAD, RAIPUR (C.G.)
CONSULTANT		RSVP ENGINEERING & PROJECT CONSULTANT CONSULTANT PRIVATE LIMITED, BHILAI (C.G.)
PROJECT:		REDESIGNING & AUGMENTATION OF ELECTRICAL POWER SYSTEM AT AIIMS, RAIPUR
DESIGNED	BY B.D SAHU	DATE 29.09.19
DRAWN	BY N.K.Y	DATE 29.09.19
APPROVED	BY UCR	DATE 30.09.19
TITLE:		PANEL TYPE -D SINGLE LINE DIAGRAM
DRG.NO.:		AIIMS/RSVP/01EE/SLD-D/EL/0154
		Rev.00

Front and side view drawing of existing LT panel (for reference only):

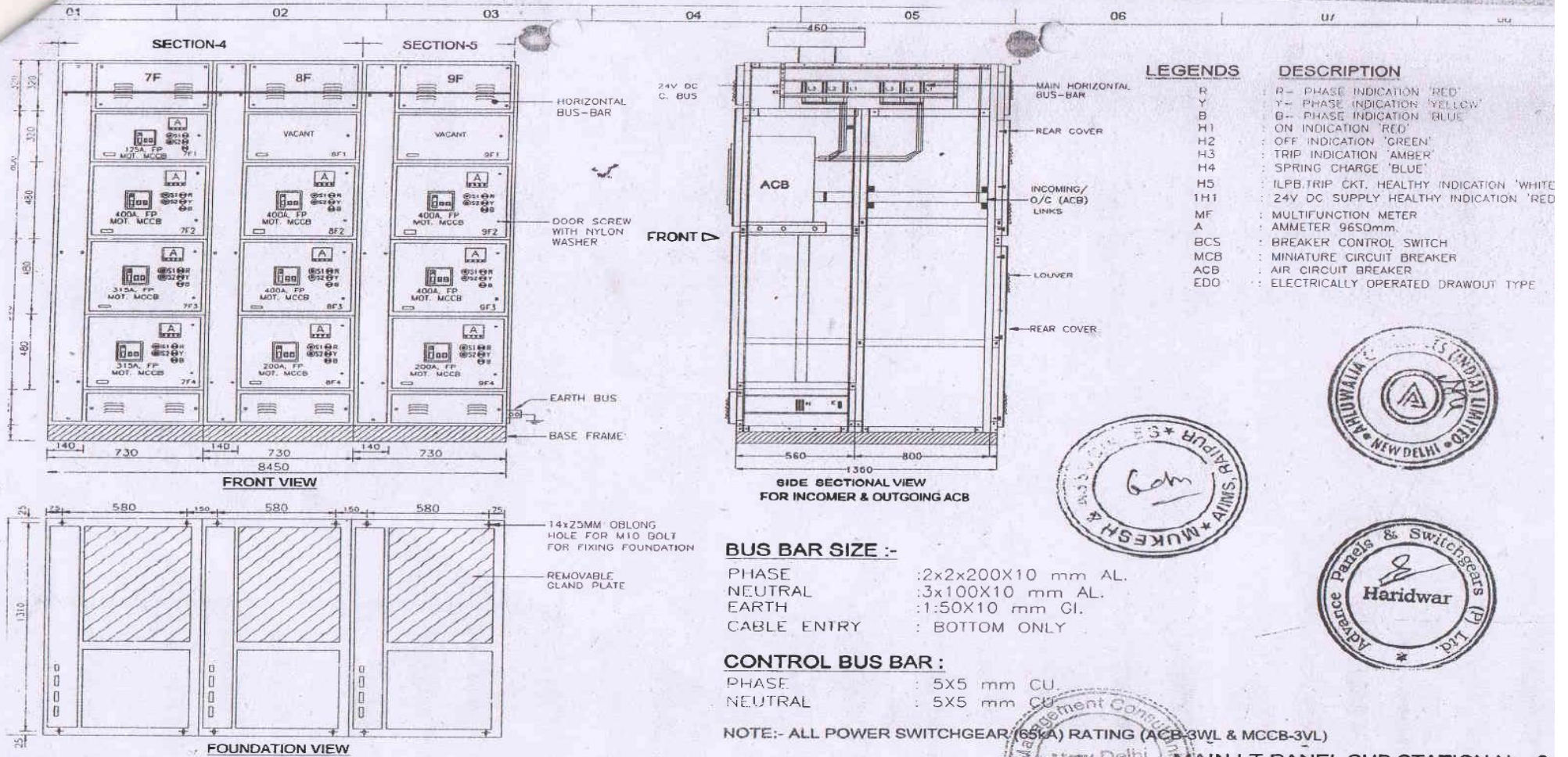

BUS BAR SIZE :-

- PHASE : 2x2x200X10 mm AL.
- NEUTRAL : 3x100X10 mm AL.
- EARTH : 1:50X10 mm GI.
- CABLE ENTRY : BOTTOM ONLY

CONTROL BUS BAR :

- PHASE : 5X5 mm CU.
- NEUTRAL : 5X5 mm CU.

NOTE:- ALL POWER SWITCHGEAR (65KA) RATING (ACB-3WL & MCCB-3VL)

SIEMENS (SIEPAN 8PU)

SIEMENS (SIEPAN 8PU)		BUS-DUCT ENTRY : TOP		CABLE ENTRY : BOTTOM		GENERAL INFORMATION		CONTACTS	
Project:	AIMS RAIPUR	Contractor:	Ahluwalia Contracts (India) Limited	Consultant:	HOSPITECH MANAGEMENT CONSULTANT (P) LTD.	Panel Design:	No. of Power Cables	No. of Fronts	Power System
End Customer:	Ministry of health and family welfare (CG)	Contact No.:	011-26015321	Cable:	Top/Bottom	Point Shade:	433V/50Hz	Ambient Temp rise:	3Ph+N+E
Contact No.:	542	Approved:	Approved	Colour:	Front access	Main Bus Size:	Control system	Temp rise:	230V AC
Site requirement:		Approved:	Approved	Size:	Rear access	Neutral Bus:	Type tested Switchboard for	45°C	
				IP protection:	Ventilation box	Earth Bus:	65KA/1Sec	Yes/No	Tel: -- FAX: --
				IP 42/IP 52	YES	Control Bus:	YES	Yes/No	email: del1@advancopanel.com
							65KA/1Sec	Yes/No	Title: MAIN LT PANEL SUB STATION No-2
							YES	Yes/No	GENERAL ARRANGEMENT DIAGRAM

**MAIN LT PANEL SUB STATION No.-2
T/C PLANT FOR HOSPITAL**

